

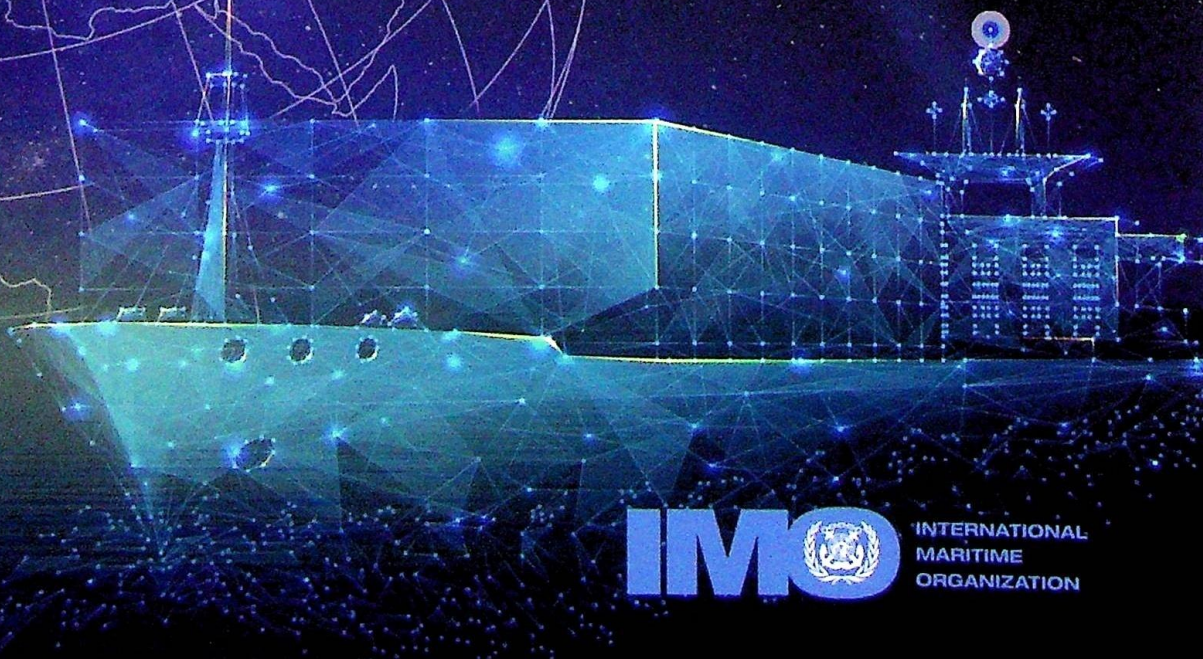

INTERNATIONAL  
**SafetyNET**  
SERVICES MANUAL

2022 Edition

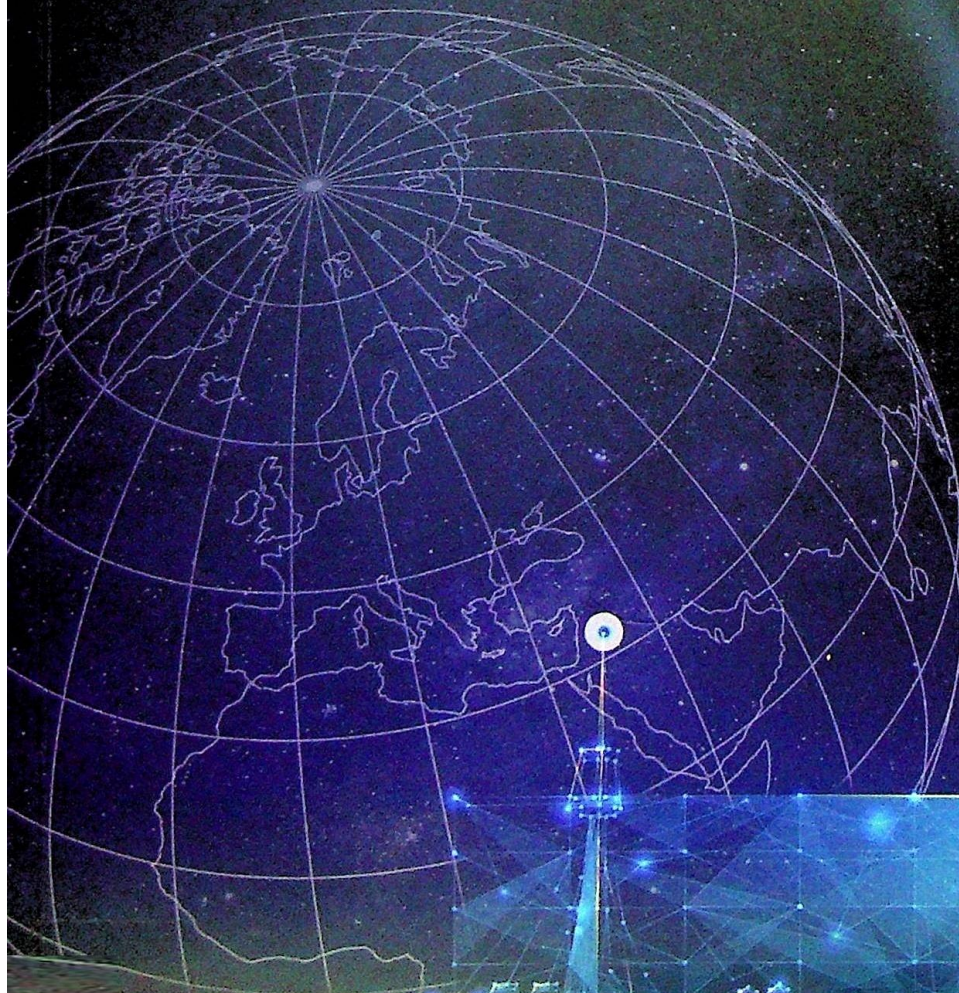

K

0014409  
623.89  
IMO



# INTERNATIONAL SafetyNET SERVICES MANUAL

2022 Edition

ACC. NO.	0014409
CLASS. NO.	623.89 IMO

CINEC CAMPUS - LIBRARY



14409



London, 2022

*First published in 1994*  
by the INTERNATIONAL MARITIME ORGANIZATION  
4 Albert Embankment, London SE1 7SR  
www.imo.org

*Fifth edition, 2022*

ISBN 978-92-801-1733-2

IMO PUBLICATION
Sales number: ID908E

Cover image based on artwork provided by Inmarsat.

*The maps on pages 9-12 (figures 3-6) are for general information purposes only and should not be construed or used as a legal description or representation. No guarantee or warranty is given that the map is spatially or temporally accurate or fit for a particular use. Coverage is subject to change at any time.*

Copyright © International Maritime Organization, 2022

*All rights reserved.  
No part of this publication may be reproduced,  
stored in a retrieval system, or transmitted in any form or by any means,  
without prior permission in writing from the  
International Maritime Organization.*

*Reproduction and/or translation rights may be available for this title.  
For further details please contact IMO Publishing at [copyright@imo.org](mailto:copyright@imo.org).*

This publication has been prepared from official documents of IMO, and every effort has been made to eliminate errors and reproduce the original text(s) faithfully. Readers should be aware that, in case of inconsistency, the official IMO text will prevail.

# Contents

---

Foreword	1
<b>1</b>	General information . . . . . 3
<b>2</b>	SafetyNET services . . . . . 3
<b>3</b>	General features of the Inmarsat EGC system . . . . . 13
<b>4</b>	Planning of new SafetyNET EGC services . . . . . 13
<b>5</b>	Changes to existing SafetyNET services . . . . . 14
<b>6</b>	Operation of International SafetyNET Services . . . . . 14
<b>7</b>	Promulgation of MSI- or SAR-related information . . . . . 16
<b>8</b>	Message formatting and C codes for SafetyNET. . . . . 17
<b>9</b>	Monitoring of MSI- and SAR-related broadcasts . . . . . 19
<b>10</b>	Accessing SafetyNET services . . . . . 20
<b>11</b>	Land earth station functions . . . . . 20
<b>12</b>	Receiving SafetyNET services broadcasts . . . . . 20
<b>13</b>	Charges for SafetyNET services. . . . . 22
<b>Annex 1</b>	The Inmarsat system. . . . . 23
<b>Annex 2</b>	Operational guidance for SafetyNET services . . . . . 25
	Part A Navigational warning services . . . . . 28
	Part B Meteorological services . . . . . 30
	Part C Search and rescue services and SAR coordination traffic. . . . . 32
	Part D Piracy countermeasures broadcast messages . . . . . 35
	Part E Repetition codes (C <sub>4</sub> ) . . . . . 38
<b>Annex 3</b>	Enhanced group call receiver specifications – Inmarsat C and mini-C . . . . . 41
<b>Annex 4</b>	Operational guidance for SafetyNET II and RescueNET . . . . . 47
<b>Annex 5</b>	Enhanced group call receiver specifications – Fleet Safety. . . . . 51
<b>Annex 6</b>	Procedure for amending the International SafetyNET Services Manual. . . . . 61

## Related information

<b>IMO Enhanced Group Call Coordinating Panel (MSC.1/Circ.1635)</b>	65
<b>Annex 1</b>	IMO Enhanced Group Call Coordinating Panel . . . . . 66
<b>Annex 2</b>	Authorization, certification and registration of enhanced group call information providers. . . . . 67
<b>Annex 3</b>	Procedure for amendment . . . . . 70



## Foreword

---

SOLAS regulation IV/12.2 states that “Every ship, while at sea, shall maintain a radio watch for broadcasts of maritime safety information on the appropriate frequency or frequencies on which such information is broadcast for the area in which the ship is navigating.”

At the request of the International Maritime Organization (IMO) Sub-Committee on Radiocommunications, the *International SafetyNET Manual* was first produced in 1994. The second edition was published in 2003 containing amendments approved at MSC 76 in December 2002, by MSC/Circ.1064.

At its seventh meeting in September 2005, the International Hydrographic Organization (IHO) Commission on the Promulgation of Radio Navigational Warnings (CPRNW)\* established a Working Group to review all World-Wide Navigational Warning Service (WWNWS) documentation. The Working Group included representation from the World Meteorological Organization (WMO) and prepared revisions to resolutions A.705(17) on *Promulgation of Maritime Safety Information* and A.706(17) on *World-Wide Navigational Warning Service*. The proposed revisions of the resolutions were circulated to IHO Member States under IHB CL 104/2007, endorsed by the Sub-Committee on Communication and Search and Rescue (COMSAR), at its twelfth session in April 2008, and subsequently approved by MSC 85 in November/December 2008 by MSC.1/Circ.1287 and MSC.1/Circ.1288, respectively.

The IHO CPRNW Working Group then prepared the revised *Joint IMO/IHO/WMO Manual on Maritime Safety Information* incorporating the revised information from resolutions A.705(17), as amended, and A.706(17), as amended. The revised text of the *Joint IMO/IHO/WMO Manual on Maritime Safety Information* was circulated to IHO Member States under cover of IHB CL 70/2008, endorsed by COMSAR 13 in January 2009 and subsequently approved by MSC 86 in May/June 2009 by MSC.1/Circ.1310.

Continuing with the holistic approach of reviewing all maritime safety information documents from the top down, the IHO WWNWS-SC Working Group prepared the third revision of the *International SafetyNET Manual*. The revised text of the *International SafetyNET Manual* was circulated to IHO Member States under cover of IHB CL 68/2009, endorsed by COMSAR 14 in March 2010 and subsequently approved by MSC 87 in May 2010 by MSC.1/Circ.1364, which became effective on 1 January 2012.

As part of its editorial review of all maritime safety information documentation, the IHO WWNWS-SC continued to review the text of the *International SafetyNET Manual*. The review took into account the amendments adopted to resolutions A.705(17) and A.706(17) and the approval of MSC.1/Circ.1310/Rev.1 on *Joint IMO/IHO/WMO Manual on Maritime Safety Information*. These changes were published as MSC.1/Circ.1287/Rev.1 and MSC.1/Circ.1288/Rev.1, which became effective on 1 January 2015, and MSC.1/Circ.1310/Rev.1, which became effective on 1 January 2016.

The fourth revision of the *International SafetyNET Manual* took place following the first session of the Sub-Committee on Navigation, Communications and Search and Rescue (NCSR) in June/July 2014 and WWNWS6 in August 2014. Subsequently, it was submitted to WMO for approval prior to submission to NCSR 3 for endorsement and final approval by MSC 97 and publication as MSC.1/Circ.1364/Rev.1, with an effective date of 1 January 2018. MSC.1/Circ.1364/Rev.1, amended by MSC.1/Circ.1364/Rev.1/Corr.1, became effective on 1 January 2020.

---

\* CPRNW was renamed as IHO WWNWS Sub-Committee (WWNWS-SC) with effect from 1 January 2009.

As a result of changes to the Inmarsat satellite network and services, the fifth revision of the *International SafetyNET Manual* took place following NCSR 6 in January 2019 and WWNWS11 in August 2019. Revisions to the Manual were submitted to WMO for approval prior to submission to NCSR 7 for endorsement and final approval at MSC 102 and publication as MSC.1/Circ.1364/Rev.2 with an effective date of 1 January 2021.\*

This edition of the Manual, renamed the *International SafetyNET Services Manual*, incorporates changes introduced to the Inmarsat satellite network and services including the Inmarsat Fleet Safety service, which has been recognized as a mobile satellite service for use in the GMDSS by adoption of resolution MSC.450(99).

---

\* As part of the revisions called for in MSC.1/Circ.1364/Rev.2, the Manual no longer includes the terms of reference for the IMO Enhanced Group Call Coordinating Panel and the procedures for authorization, certification and registration of enhanced group call information providers. This information is given in MSC.1/Circ.1635 and is reproduced in the related information section of this publication.

## **1 General information**

**1.1** SafetyNET is an international automatic direct-printing satellite-based service for the promulgation of maritime safety information (MSI), navigational and meteorological warnings, meteorological forecasts, search and rescue (SAR) related information and other urgent safety-related messages to ships. It has been developed as a safety service of the Inmarsat C enhanced group call (EGC) system to provide a simple and automated means of receiving MSI- and SAR-related information on board ships at sea. The message-selection features of SafetyNET receivers enable mariners to receive safety information broadcasts that are tailored to their particular needs.

**1.2** As a part of Inmarsat's Global Maritime Distress and Safety System (GMDSS) modernization programme, SafetyNET II and RescueNET were developed by Inmarsat with the support from the wider maritime community in 2017. SafetyNET II, introduced in document NCSR 5/14/5, is an enhancement of the existing SafetyNET service, within the EGC system. RescueNET provides SafetyNET II services for SAR-related broadcasts and other SAR services. For additional information on SafetyNET II and RescueNET, see annex 4.

**1.3** In regard to this Manual, the term SafetyNET services will refer to SafetyNET, SafetyNET II and RescueNET. SafetyNET services fulfil an integral role in the GMDSS developed by the International Maritime Organization (IMO), as defined in the International Convention for the Safety of Life at Sea (SOLAS), 1974, as amended, as a requirement for ships to which the Convention applies.

**1.4** Fleet Safety is the digital satellite communications system comprising a FleetBroadband ship earth station (SES) and type-approved Maritime Safety Terminal (MST) for use within the GMDSS, enabling ships to meet the majority of the satellite communications requirements of the GMDSS, including distress alerting, reception of MSI- and SAR-related information, voice distress and general communications.

**1.5** This Manual describes the structure and operation of the International SafetyNET services. It is intended primarily for national Administrations and registered information providers, but it may also be useful to the mariner who requires more operational information than is found in manufacturers' equipment manuals.

## **2 SafetyNET services**

### **2.1 Introduction**

**2.1.1** SafetyNET services provide shipping with navigational and meteorological warnings, meteorological forecasts, shore-to-ship distress alerts, SAR-related information and other urgent information in accordance with the requirements of SOLAS. It is suitable for use in all sizes and types of ships. Figure 1 illustrates the way the services are structured.

**2.1.2** SafetyNET services are a part of the EGC system and are specifically designed for promulgation of MSI- and SAR-related information within the GMDSS. The EGC system provides an automatic method of broadcasting messages to both fixed and variable geographical areas. It is designed with the capability to provide services within the coverage areas of geostationary satellites, known as "ocean regions" (approximately between 76°N and 76°S). In addition to providing services to ships operating in sea area A3, it also provides the means of broadcasting MSI to coastal warning areas not covered by the International NAVTEX service.

**2.1.3** SafetyNET services offer the ability to direct a message to a given geographical area. The area may be fixed, as in the case of a NAVAREA/METAREA or coastal warning area, or a user-defined area (circular or rectangular). A user-defined area is used for messages, such as a local storm warning or a shore-to-ship distress alert, for which it is inappropriate to alert ships in an entire satellite ocean region or NAVAREA/METAREA. The general EGC system capabilities are shown in figure 2.

**2.1.4** SafetyNET messages are submitted by registered information providers for promulgation to the appropriate satellite ocean region(s) via an Inmarsat C land earth station (LES).



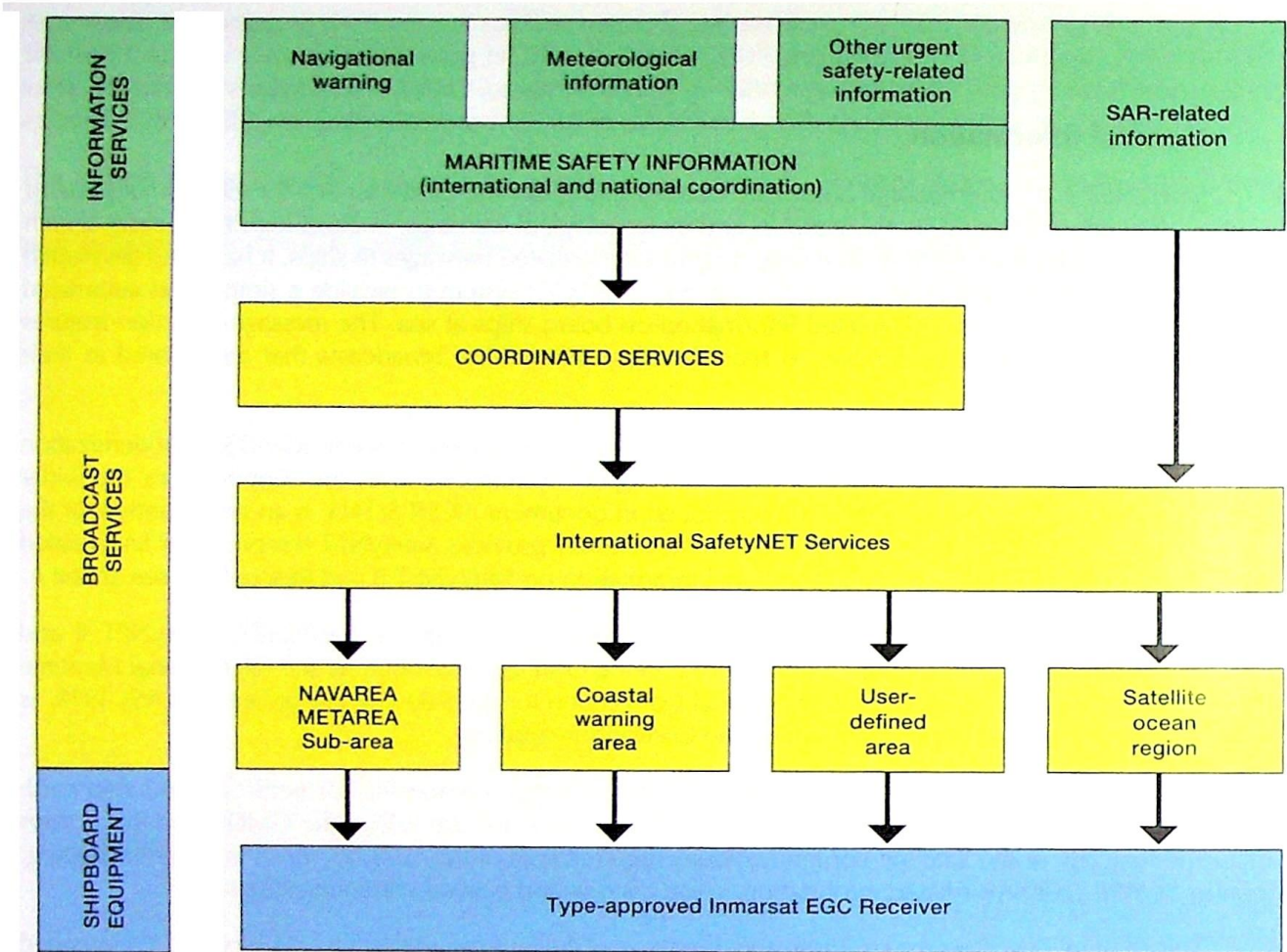

Figure 1 – International SafetyNET services system

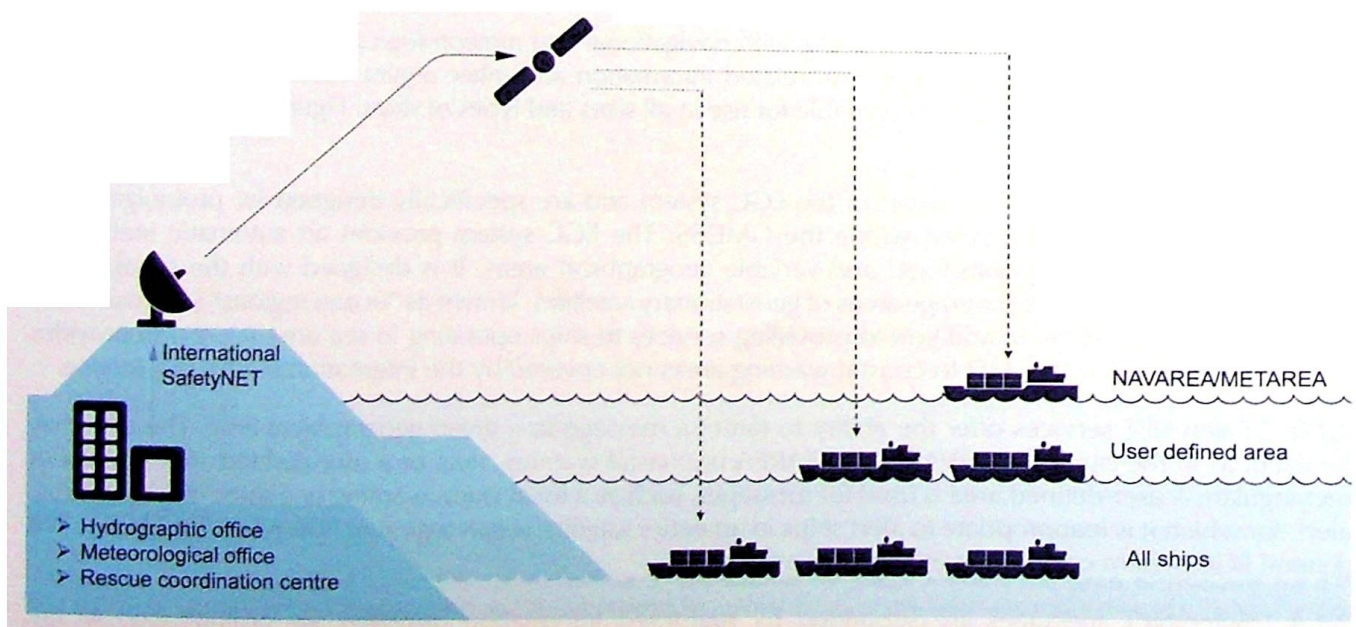

Figure 2 – Basic concept of the International SafetyNET services

2.1.5 SafetyNET II messages are submitted by registered information providers via a secure interface to the Inmarsat network. See annex 4 for more information.

2.1.6 Messages are broadcast according to their priority, i.e. distress, urgency or safety. Aboard ships, messages are received by type-approved Inmarsat ship earth station EGC terminals.

## 2.2 Definitions

2.2.1 For the purposes of this Manual, the following definitions apply:

- .1 *Coastal warning* means a navigational warning or in-force bulletin promulgated as part of a numbered series by a national coordinator. Broadcast should be made by the International NAVTEX service to defined NAVTEX service areas and/or by the International SafetyNET services to coastal warning areas. In addition, Administrations may issue coastal warnings by other means.
- .2 *Coastal warning area* means a unique and precisely defined sea area within a NAVAREA/METAREA or sub-area established by a coastal State for the purpose of coordinating the promulgation of coastal maritime safety information through an international enhanced group call service.
- .3 *Coastal and offshore waters* apply to areas for which WMO Members issue weather and sea bulletins, governed by the procedures in the Manual on Marine Meteorological Services (WMO No.558).
- .4 *Enhanced group call (EGC)* means the international broadcast of coordinated maritime safety information and search and rescue related information, to a defined geographical area using a recognized mobile satellite service.
- .5 *Fleet Safety* means the digital satellite communications system comprising a FleetBroadband ship earth station and type-approved Maritime Safety Terminal for use within the Global Maritime Distress and Safety System, enabling ships to meet the majority of the satellite communications requirements of the Global Maritime Distress and Safety System, including distress alerting, reception of maritime safety information, search and rescue related information, voice distress and general communications.
- .6 *Global Maritime Distress and Safety System (GMDSS)* means a system that performs the functions set out in SOLAS regulation IV/4.
- .7 *HF NBDP* means high-frequency narrow-band direct printing, using radiotelegraphy as defined in Recommendation ITU-R M.688, as amended.
- .8 *In-force bulletin* means a list of serial numbers of those NAVAREA, sub-area or coastal warnings in force issued and promulgated by the NAVAREA Coordinator, sub-area coordinator or national coordinator.
- .9 *Inmarsat C* means the digital satellite communications system for store-and-forward text or data messaging using mobile terminals with omni-directional antennas. Inmarsat C allows ships to meet the majority of the satellite communications requirements of the Global Maritime Distress and Safety System, including distress alerting, reception of maritime safety information, search and rescue related information and general communications.
- .10 *Inmarsat mini-C* means smaller terminals, based on the same technical requirements as Inmarsat C terminals. Some models are approved as Global Maritime Distress and Safety System compliant terminals.
- .11 *International enhanced group call service* means the coordinated broadcast and automatic reception of maritime safety information and search and rescue related information via enhanced group call, using the English language.
- .12 *Inmarsat Fleet* means the digital satellite communications system that provides voice and flexible data communication services, email and secure internet access for maritime users, comprising

- Fleet F77. The Inmarsat Fleet F77 system provides voice distress and safety functionality and meets the requirements of resolution A.1001(25).
- .13 *Inmarsat FleetBroadband* means the communication service that provides voice and high-speed data services, simultaneously, through compact terminals for maritime users.
  - .14 *International NAVTEX service* means the coordinated broadcast and automatic reception on 518 kHz of maritime safety information by means of narrow-band direct-printing telegraphy using the English language.\*
  - .15 *International RescueNET service* means Inmarsat's SafetyNET service provided to search and rescue authorities for broadcasting and automated reception of search and rescue related messages on Inmarsat approved terminals including Inmarsat C, mini-C and Fleet Safety, via an interactive web-based interface, using the English language, in accordance with the provisions of the International Convention for the Safety of Life at Sea, 1974, as amended.
  - .16 *International SafetyNET service* means the coordinated broadcast and automatic reception of maritime safety information via the Inmarsat enhanced group call system, using the English language, in accordance with the provisions of the International Convention for the Safety of Life at Sea, 1974, as amended.
  - .17 *International SafetyNET II service* means Inmarsat's enhancement to the SafetyNET service, providing coordinated broadcasting and automated reception of maritime safety information on Inmarsat approved terminals including Inmarsat C, mini-C and Fleet Safety, via an interactive web-based interface, using the English language, in accordance with the provisions of the International Convention for the Safety of Life at Sea, 1974, as amended.
  - .18 *Issuing service* means a National Meteorological and Hydrological Service or National Authority which has accepted responsibility for ensuring that meteorological warnings and forecasts for shipping are disseminated through the international enhanced group call service to the designated METAREA for which the National Meteorological and Hydrological Service or National Authority has accepted responsibility under the broadcast requirements of the Global Maritime Distress and Safety System.
  - .19 *Land earth station (LES)* means a fixed terrestrial station acting as a gateway between terrestrial communication networks and the Inmarsat satellites in the maritime mobile-satellite service. This may also be referred to as a coast earth station.
  - .20 *Land earth station operator* means an Inmarsat service provider which owns and operates the land earth station.
  - .21 *Local warning* means a navigational warning which covers inshore waters, often within the limits of jurisdiction of a harbour or port authority.
  - .22 *Maritime safety information (MSI)*† means navigational and meteorological warnings, meteorological forecasts and other urgent safety-related messages broadcast to ships.
  - .23 *Maritime safety information service* means the internationally and nationally coordinated network of broadcasts containing information which is necessary for safe navigation.
  - .24 *METAREA* means a geographical sea area‡ established for the purpose of coordinating the broadcast of marine meteorological information. The term METAREA followed by a roman numeral may be used to identify a particular sea area. The delimitation of such areas is not related to and should not prejudice the delimitation of any boundaries between States (see figures 3 and 4).

---

\* As set out in the IMO NAVTEX Manual.

† As defined in SOLAS regulation IV/2.

‡ Which may include inland seas, lakes and waterways navigable by seagoing ships.

- .25 *METAREA coordinator* means the individual with the authority to coordinate marine meteorological information broadcasts by one or more national meteorological and hydrological services acting as preparation or issuing services within the METAREA.
- .26 *Meteorological information* means the marine meteorological warnings and forecast information in accordance with the provisions of the International Convention for the Safety of Life at Sea, 1974, as amended.
- .27 *Maritime Safety Terminal (MST)* means an Inmarsat type-approved safety terminal for use within the Fleet Safety system.
- .28 *National coordinator* means the national authority charged with collating and issuing coastal warnings within a national area of responsibility.
- .29 *National enhanced group call service* means the broadcast and automatic reception of maritime safety information via the EGC system, using languages as decided by the Administration concerned.
- .30 *NAVAREA* means a geographical sea area\* established for the purpose of coordinating the broadcast of navigational warnings. The term NAVAREA followed by a roman numeral may be used to identify a particular sea area. The delimitation of such areas is not related to and should not prejudice the delimitation of any boundaries between States (see figures 5 and 6).
- .31 *NAVAREA coordinator* means the authority charged with coordinating, collating and issuing NAVAREA warnings for a designated NAVAREA.
- .32 *NAVAREA warning* means a navigational warning or in-force bulletin promulgated as part of a numbered series by a NAVAREA coordinator.
- .33 *Navigational warning* means a message containing urgent information relevant to safe navigation broadcast to ships in accordance with the provisions of the International Convention for the Safety of Life at Sea, 1974, as amended.
- .34 *Network coordination station (NCS)* means a fixed land station in the Inmarsat satellite communications system which controls channel assignments and provides the network management functions for each of the four ocean regions. NCSs also transmit EGC messages on the NCS common channel.
- .35 *Other urgent safety-related information* means maritime safety information broadcast to ships that is not defined as a navigational warning or meteorological information. This may include, but is not limited to, significant malfunctions or changes to maritime communications systems, and new or amended mandatory ship reporting systems or maritime regulations affecting ships at sea.
- .36 *Preparation service* means a national meteorological and hydrological service or national authority which has accepted responsibility for the preparation of warnings and forecasts and warnings for parts of or an entire METAREA in the WMO system for the dissemination of meteorological forecasts to shipping under the GMDSS and for their transfer to the relevant issuing service for broadcast.
- .37 *Registered information provider* means a maritime safety information provider or a search and rescue related information provider, authorized in accordance with annex 2 of the *IMO Enhanced Group Call Coordinating Panel* (MSC.1/Circ.1635).
- .38 *Rescue coordination centre (RCC)* means a unit responsible for promoting efficient organization of search and rescue services and for coordinating the conduct of search and rescue operations within a search and rescue region. Note: the term RCC will be used within this Manual to apply to either joint, aeronautical or maritime centres; JRCC, ARCC or MRCC will be used as the context warrants.

---

\* Which may include inland seas, lakes and waterways navigable by seagoing ships.

- .39 *Search and rescue (SAR) related information* means distress alert relays and other urgent search and rescue related information broadcast to ships.
- .40 *Satellite ocean region* means the area on the earth's surface within which a mobile or fixed antenna can obtain line-of-sight communications with one of the five primary Inmarsat geostationary satellites. This area may also be referred to as the satellite "footprint".
- .41 *Sea area A1* means an area within the radiotelephone coverage of at least one VHF coast station in which continuous DSC\* alerting is available, as may be defined by a SOLAS Contracting Government.
- .42 *Sea area A2* means an area, excluding sea area A1, within the radiotelephone coverage of at least one MF coast station in which continuous DSC alerting is available, as may be defined by a SOLAS Contracting Government.
- .43 *Sea area A3* means an area, excluding sea areas A1 and A2, within the coverage of an Inmarsat geostationary satellite in which continuous alerting is available.
- .44 *Sea area A4* means an area outside sea areas A1, A2 and A3.
- .45 *Ship earth station (SES)†* means a mobile earth station in the recognized mobile satellite service located on board a ship. This may also be referred to as a mobile earth station (MES).
- .46 *Sub-area* means a subdivision of a NAVAREA/METAREA in which a number of countries have established a coordinated system for the promulgation of maritime safety information. The delimitation of such areas is not related to and should not prejudice the delimitation of any boundaries between States.
- .47 *Sub-area coordinator* means the authority charged with coordinating, collating and issuing sub-area warnings for a designated sub-area.
- .48 *Sub-area warning* means a navigational warning or in-force bulletin promulgated as part of a numbered series by a sub-area coordinator. Broadcast should be made by the International NAVTEX service to defined NAVTEX service areas or by the international enhanced group call service (through the appropriate NAVAREA coordinator).
- .49 *User-defined area* means a temporary geographic area, either circular or rectangular, to which maritime safety information is addressed.
- .50 *UTC* means Coordinated Universal Time which is equivalent to GMT (Z) as the international time standard.
- .51 *Worldwide Met-Ocean Information and Warning Service (WWMIWS)‡* means the internationally coordinated service for the promulgation of meteorological warnings and forecasts.
- .52 *Worldwide Navigational Warning Service (WWNWS)§* means the internationally and nationally coordinated service for the promulgation of navigational warnings.
- .53 In the operating procedures, *coordination* means that the allocation of the time for data broadcast is centralized, the format and criteria of data transmissions are compliant as described in the *Joint IMO/IHO/WMO Manual on Maritime Safety Information* and that all services are managed as set out in resolutions A.705(17), as amended, A.706(17), as amended, and A.1051(27), as amended.

---

\* Digital selective calling (DSC) means a technique using digital codes, conforming to the technical structure and content set forth in the most recent version of Recommendations ITU-R M.493 and ITU-R M.541, which enables a radio station to establish contact with, and transfer information to, another station or group of stations.

† SES within this document refers to a type-approved EGC capable ship earth station.

‡ See resolution A.1051(27), as amended.

§ See resolution A.706(17), as amended.

2.2.2 METAREAs with Inmarsat satellite ocean region coverage

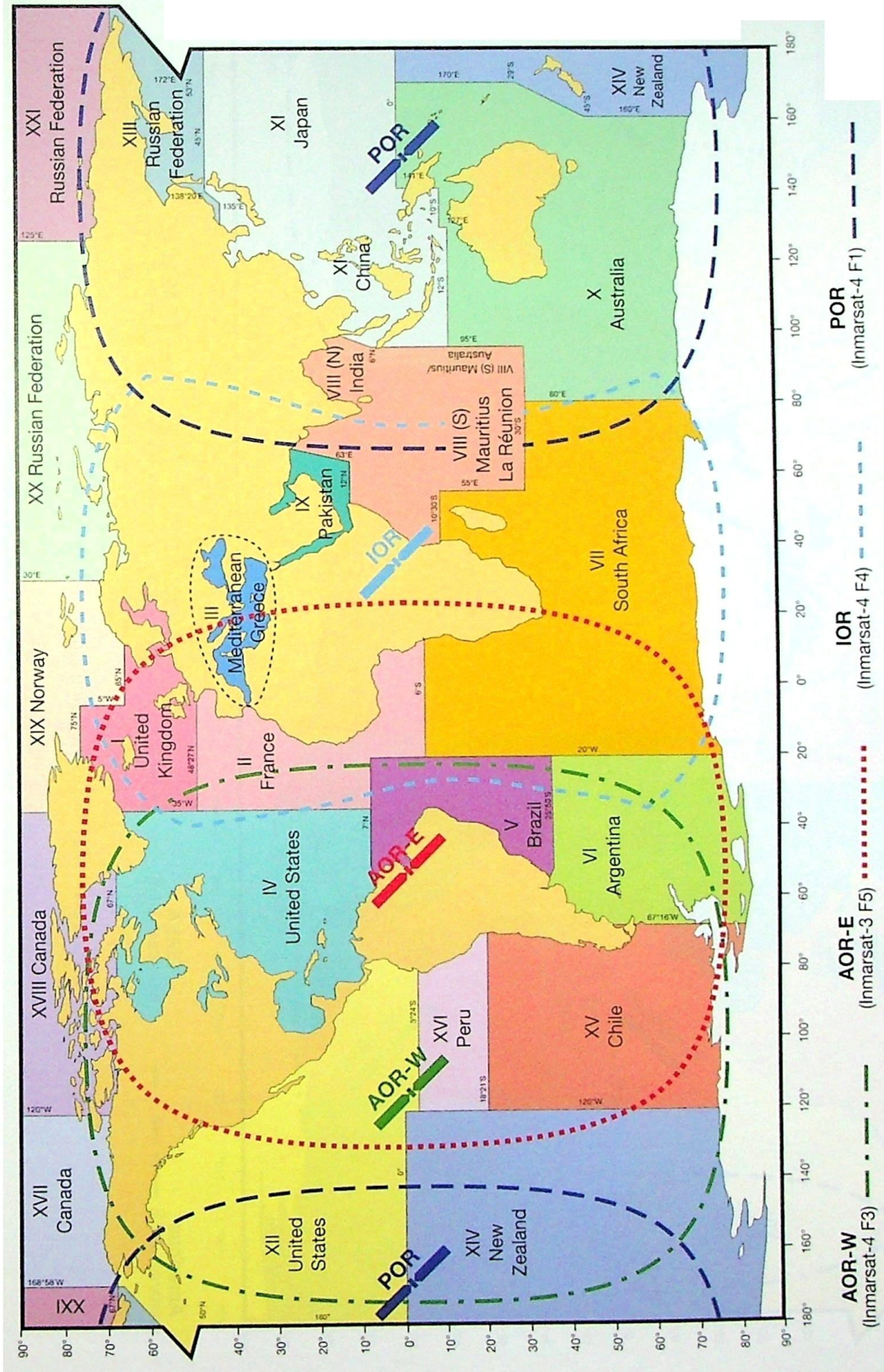

Figure 3 – METAREAs including Inmarsat C coverage

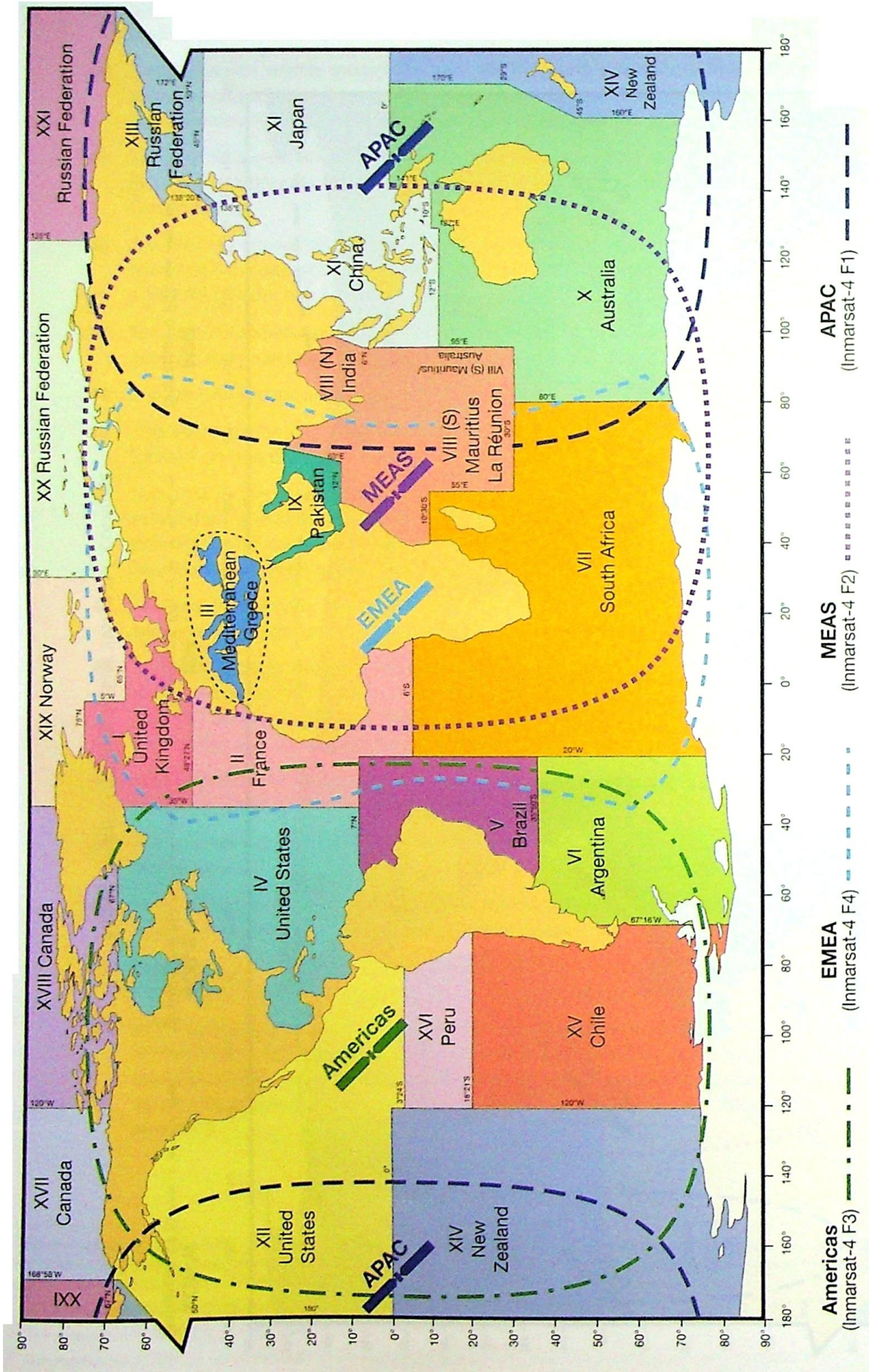

Figure 4 – METAREAs including Inmarsat FleetBroadband coverage

2.2.3 NAVAREAs with Inmarsat satellite ocean region coverage

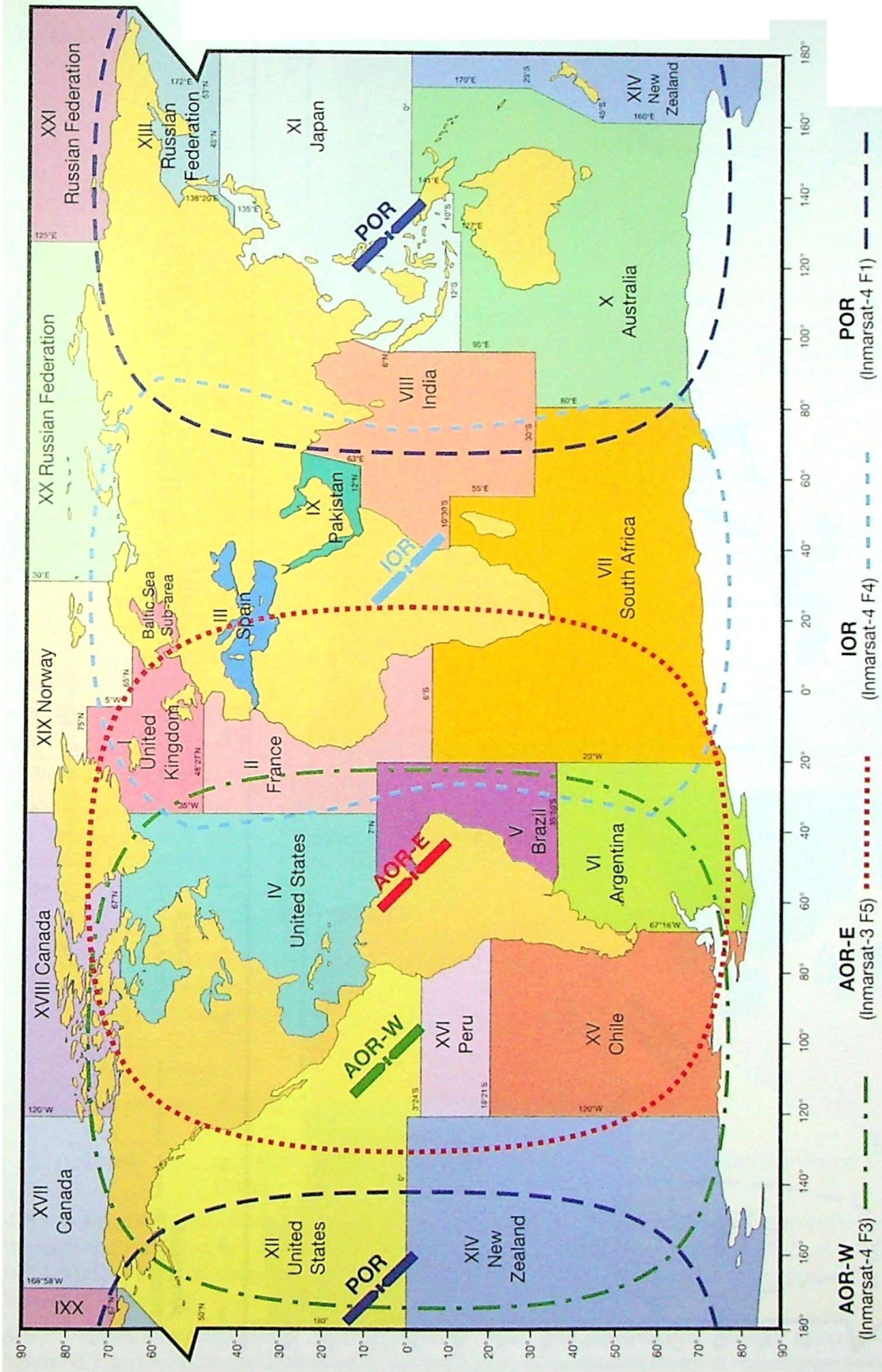

Figure 5 – NAVAREAs including Inmarsat C coverage



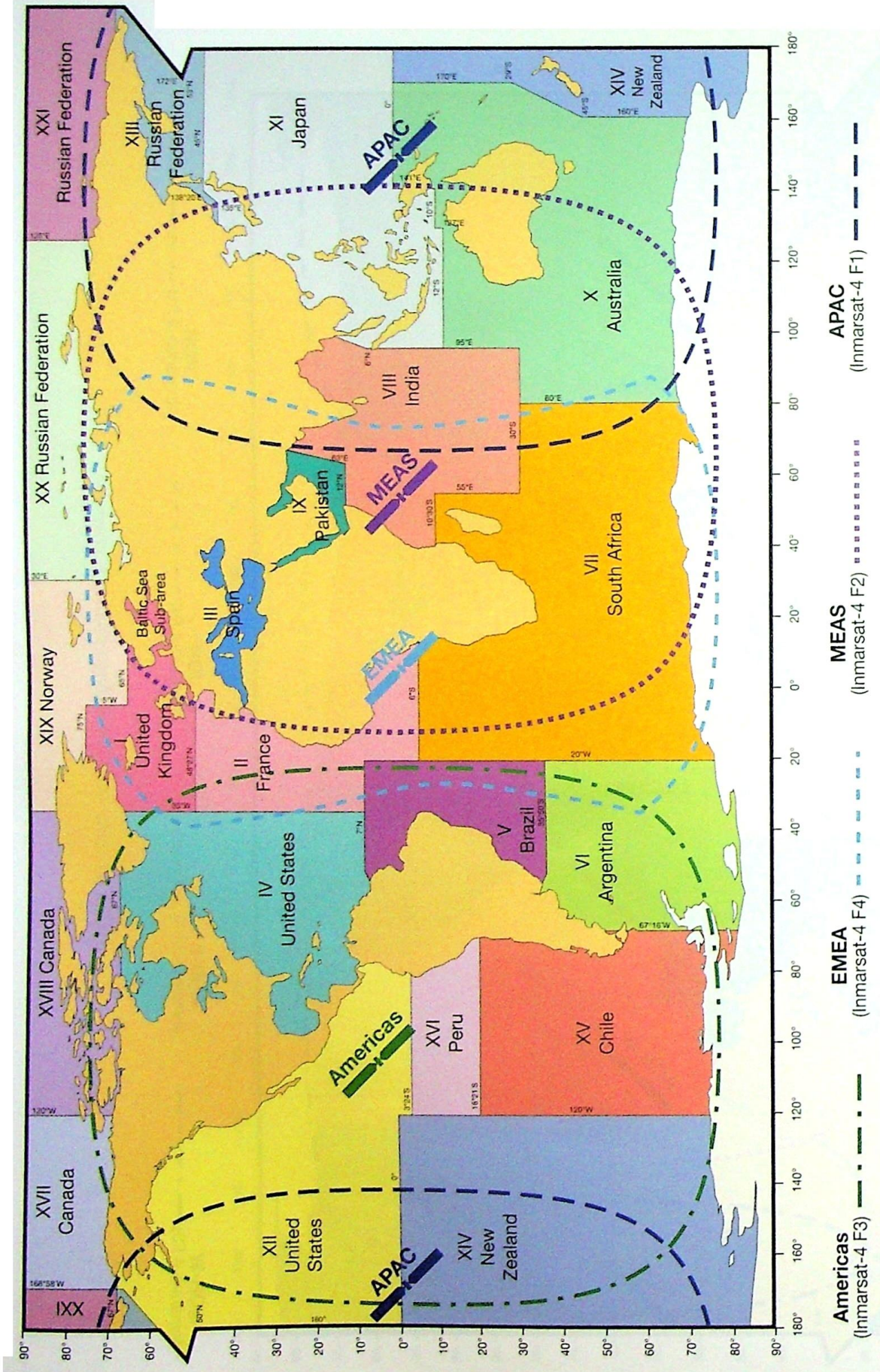

Figure 6 – NAVAREAs including Inmarsat FleetBroadband coverage

### 3 General features of the Inmarsat EGC system

3.1 The Inmarsat EGC system supports SafetyNET services for promulgation of MSI- and SAR-related information.

- .1 SafetyNET/SafetyNET II – for broadcast and automated reception of MSI- and SAR-related information; and
- .2 RescueNET – for broadcast and automated reception of SAR-related information.

3.2 All navigable waters of the world between 76°N and 76°S are covered by satellites in the Inmarsat system. Each satellite transmits EGC messages on a designated channel; this channel is optimized to enable the signal to be received by type-approved Inmarsat EGC terminals. Reception of EGC messages is normally not affected by the position of the ship within the satellite ocean region, atmospheric conditions or time of day.

3.3 SafetyNET services broadcasts are addressed to a geographical area (area calls). These area calls can be addressed to a fixed geographical area (NAVAREA/METAREA or coastal warning area) or to a user-defined area selected by an information provider. Area calls will be received automatically by any Inmarsat EGC receiver within the area. To receive EGC coastal warnings, the Inmarsat EGC receiver must be set up with appropriate codes (see section 12.4).

### 4 Planning of new SafetyNET EGC services

4.1 Authorities wishing to become officially registered information providers of MSI- and SAR-related information to ships at sea via SafetyNET services should contact IMO via the IMO EGC Coordinating Panel at an early stage for advice. The plans of any prospective registered information providers should be coordinated with IMO, IHO and WMO and with other national authorities, before authorization to broadcast via SafetyNET services may be granted by the IMO EGC Coordinating Panel, in accordance with the procedures set out in annex 2 of the *IMO Enhanced Group Call Coordinating Panel (MSC.1/Circ.1635)*.

4.2 Once authorized and registered, information providers should contact Inmarsat, in order to determine specific details for addressing messages, accessing the Inmarsat services, charges and payment for services and any other matters with respect to providing MSI- and SAR-related information to mariners.

4.3 The IMO EGC Coordinating Panel, in cooperation with IHO and WMO, undertakes the coordination of times for scheduled transmissions.

4.4 Authorities should seek approval from the IMO EGC Coordinating Panel, at the address given below, for any changes to existing scheduled broadcast times. Within the submission, authorities should include details of the proposed broadcast times, service description, and satellite ocean region or coastal warning area.

The Chair

IMO Enhanced Group Call Coordinating Panel

International Maritime Organization

4 Albert Embankment

London SE1 7SR

United Kingdom

Telephone: +44 (0)20 7735 7611

Fax: +44 (0)20 7587 3210

Email: ncsr@imo.org (in subject line add: for Chair, IMO Enhanced Group Call Coordinating Panel)

4.5 Mariners should be informed of the establishment of a SafetyNET service by the information provider through the inclusion of full details in Notices to Mariners and other national nautical publications and the IMO Master Plan of shore-based facilities for the GMDSS in the Global Integrated Shipping Information System (GISIS).

4.6 Questions concerning promulgation of MSI- and SAR-related related information through the SafetyNET services can be addressed to the IMO EGC Coordinating Panel at the address above.

**4.7** Questions concerning the operation of the SafetyNET services should be addressed to:

Maritime Safety Services  
Inmarsat Global Ltd  
99 City Road  
London EC1Y 1AX  
United Kingdom

Email: maritime.safety@inmarsat.com

## **5 Changes to existing SafetyNET services**

**5.1** Registered information providers wishing to change their existing SafetyNET service should follow the same coordination procedures as for a new service, in accordance with the procedures set out in section 4.

**5.2** The IMO EGC Coordinating Panel, in cooperation with IHO and WMO, undertakes the coordination of times for scheduled broadcasts.

**5.3** Registered information providers should seek approval from the IMO EGC Coordinating Panel, at the address given in section 4, for any changes to existing scheduled broadcast times. Within the submission, registered information providers should include updated details of proposed broadcast times, service description, and satellite ocean region or coastal warning area.

**5.4** Once approved by the IMO EGC Coordinating Panel, registered information providers should inform mariners of the changes to existing SafetyNET services by the information provider through the inclusion of full details in Notices to Mariners and other national nautical publications and the IMO Master Plan of shore-based facilities for the GMDSS.

## **6 Operation of International SafetyNET Services**

**6.1** Given the size of a satellite ocean region, some form of selectivity in receiving and printing the various messages is required. All ships within the footprint of a selected satellite will receive area calls; however, they will only be displayed and printed by those receivers that recognize both:

- .1 the fixed geographical area (NAVAREA/METAREA), user-defined area as appropriate; and
- .2 for coastal warnings, the coastal warning area and the subject indicator for the message.

**6.2** The message format includes a preamble which enables SESs to display and print only those messages which relate to its present position, to the intended route, or to the aforementioned areas as programmed by the operator.

**6.3** For coastal warning areas messages, the registered information provider must ensure that the preamble includes the identifier allocated for the particular area, along with the appropriate subject indicator (see section 12.4). SES can be set to reject messages concerning certain optional subjects which may not be required by the ship. SES also uses the subject indicator to identify coastal warnings which, because of their importance, may not be rejected.

**6.4** Reception of certain types of messages, such as shore-to-ship distress alert relays, SAR-related information, meteorological warnings and forecasts and navigational warnings, addressed to a geographical area within which SES is located, is mandatory and cannot be suppressed by ships in the affected area. These messages are identified by the C<sub>2</sub> service codes: 00, 04, 14, 24, 31, 34 and 44 (see annex 2).

**6.5** When a message has been received error-free, a record is made of the message identification (the unique sequence number, the unique identifier and the service code) associated with that message. The unique sequence number is used to suppress the printing of repeated transmissions of the same message.

**6.6** A SES is capable of storing at least 255 message identifications. These message identifications are stored with an indication of the number of hours that have elapsed since the last receipt of the message. Subsequent reception of the same message identification will reset this timer. After between 60 and 72 hours, message identifications may be automatically erased. If the number of received message identifications exceeds the capacity of memory allocated, the oldest message identification will be erased.

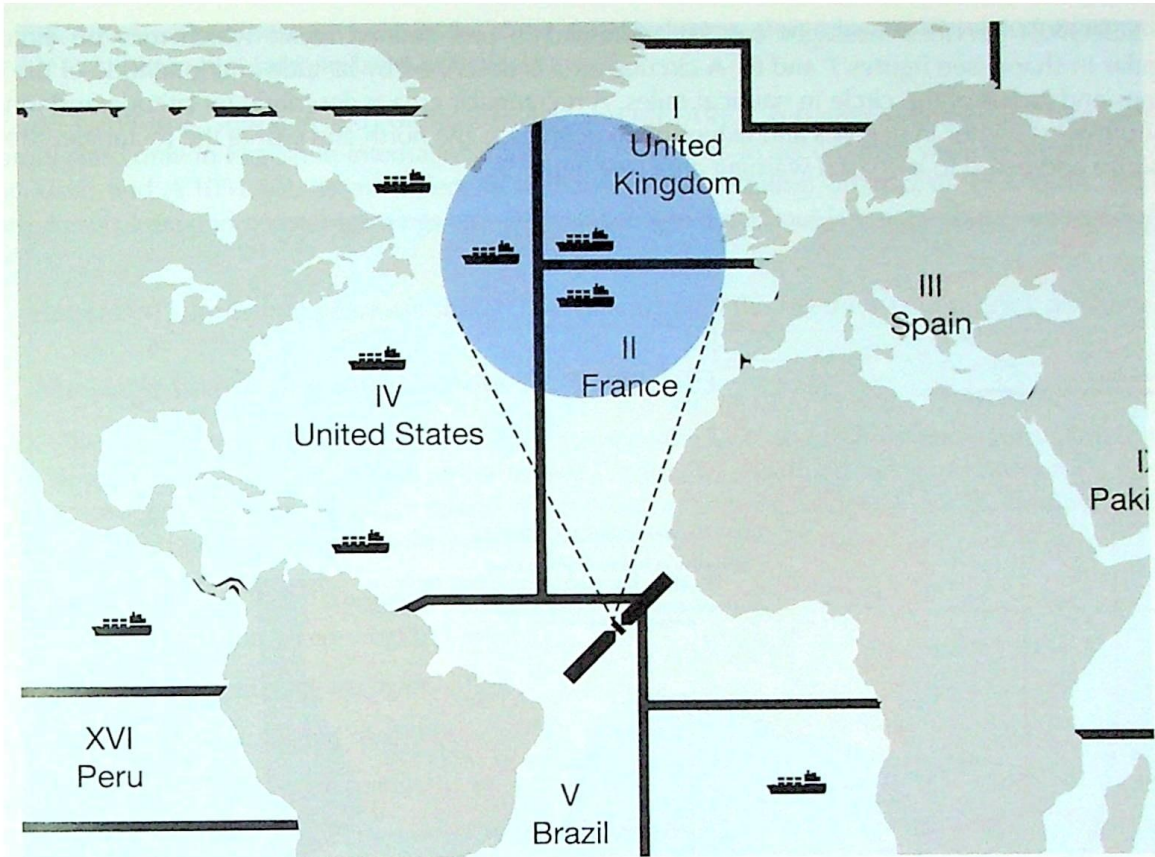

Figure 7 – SafetyNET services message addressing to a circular area

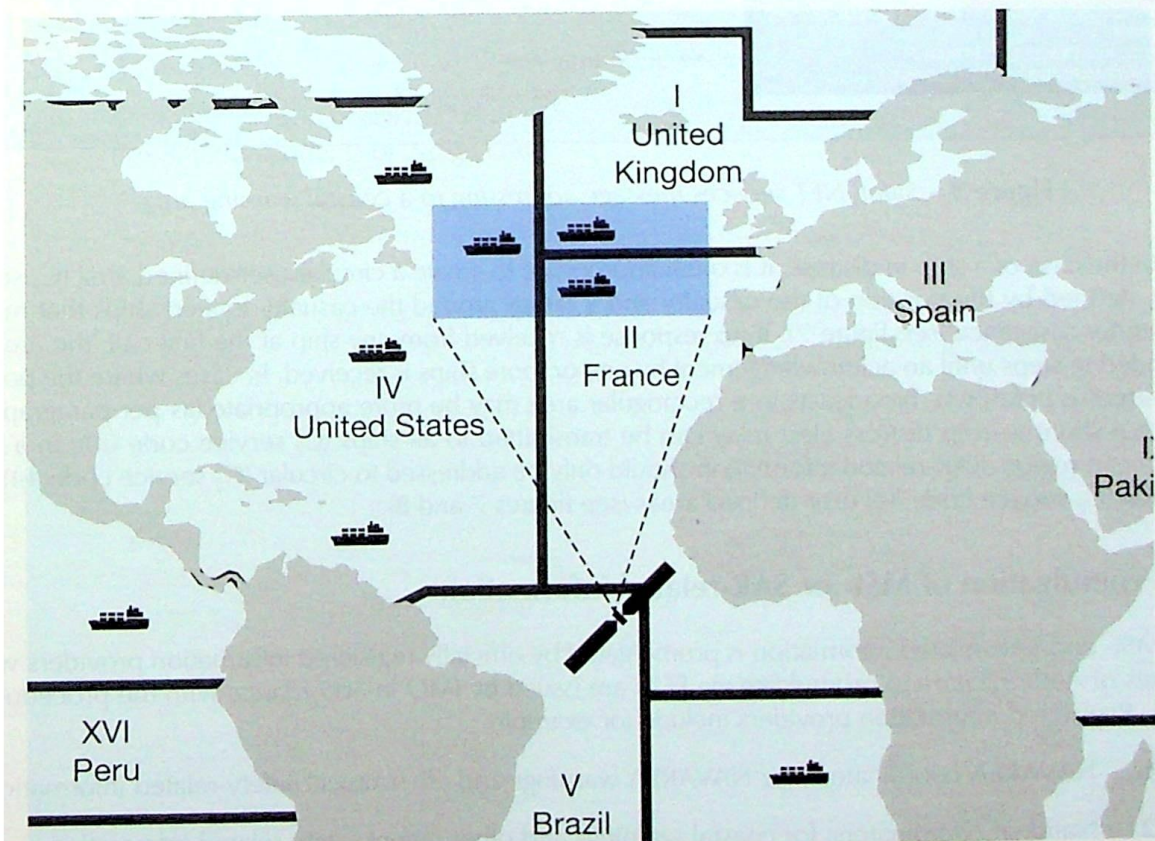

Figure 8 – SafetyNET services message addressing to a rectangular area

6.7 SafetyNET services messages can be addressed to user-defined areas, which may be circular or rectangular in shape (see figures 7 and 8). A circular area is described by latitude and longitude of the centre in degrees and radius of the circle in nautical miles. A rectangular area is described by latitude and longitude of the south-west corner in degrees and extension in degrees to the north and east of the rectangle. Messages may also be addressed to a coastal warning area (see figure 9).

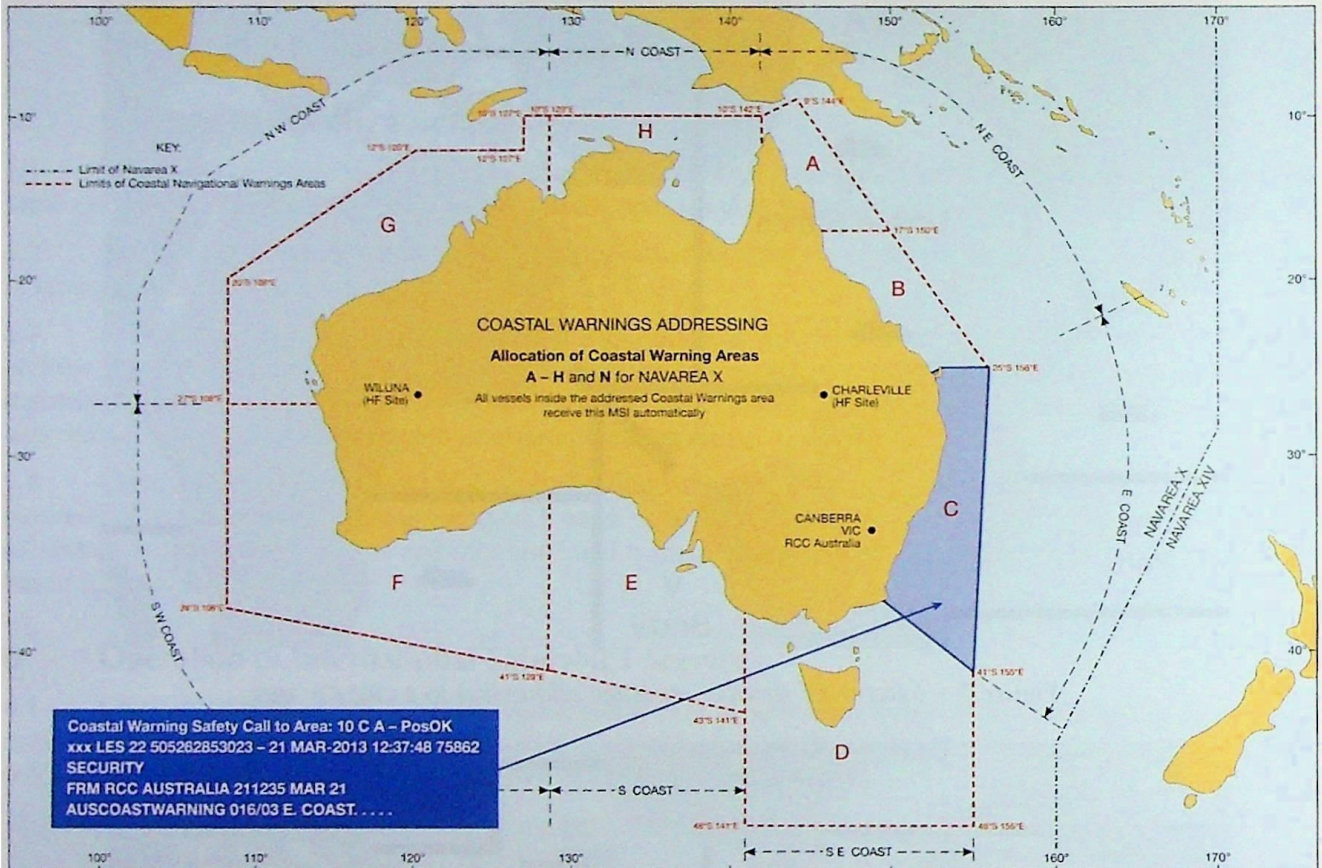

Figure 9 – SafetyNET services message addressing to a coastal warning area

6.8 In the case of a ship in distress, it is often appropriate to create a circular user-defined area ( $C_2$  service code 14), defined by the position of the casualty and a radius around the casualty to alert ships that may be able to render assistance (see figure 7). If no response is received from any ship at the first call, the area can be expanded in steps until an acknowledgement by one or more ships is received. In cases where the position of the distress is unknown, broadcasts to a rectangular area may be more appropriate (as per paragraph 6.7 above), or a shore-to-ship distress alert relay can be transmitted to all ships ( $C_2$  service code 00), in a given satellite ocean region. SAR-related information should only be addressed to circular ( $C_2$  service code 44) or to rectangular ( $C_2$  service code 34) user-defined areas (see figures 7 and 8).

## 7 Promulgation of MSI- or SAR-related information

7.1 MSI- and SAR-related information is promulgated by officially registered information providers whose Certificates of Authorization to promulgate via EGC are issued by IMO in accordance with the procedures in section 4. Registered information providers include for example:

- .1 NAVAREA coordinators: for NAVAREA warnings and other urgent safety-related information;
- .2 National coordinators: for coastal warnings and other urgent safety-related information;
- .3 METAREA coordinators: for meteorological warnings and forecasts; and

- .4 Rescue coordination centres: for shore-to-ship distress alert relays, SAR-related information and other urgent safety-related information.

7.2 All NAVAREA, sub-area and coastal warnings and METAREA, sub-area warnings and forecasts should be promulgated only in English in International SafetyNET Services in accordance with resolutions A.706(17), as amended, and A.1051(27), as amended. In addition to the required broadcasts in English, METAREA/NAVAREA, sub-area and coastal warnings may be broadcast in a national language using national SafetyNET services.

7.3 Registered information providers should take into account the need for contingency planning.

## 8 Message formatting and C codes for SafetyNET\*

8.1 EGC messages include instructions to LES for processing MSI- and SAR-related information in the form of a special address header that consists of five (or six) C codes as described below. In order for a message to be correctly processed, it should always consist of data conforming to C codes "1" to "5". Additionally, C code "0" should be used when required by the service provider.

C<sub>0</sub> Ocean region code – 1-digit (when required)

0 – Atlantic Ocean region – west

1 – Atlantic Ocean region – east

2 – Pacific Ocean region

3 – Indian Ocean region

9 – All ocean regions served by the addressed LES.

(Note: Availability of C<sub>0</sub> = 9 should be checked with the LES operator or service provider.)

C<sub>1</sub> Priority code: 1-digit code

C<sub>2</sub> Service code: 2-digit code

C<sub>3</sub> Address code: 2, 4, 10 or 12 alphanumeric code

C<sub>4</sub> Repetition code: 2-digit code

C<sub>5</sub> Presentation code: 1- or 2-digit code

\* Refer to annexes 2 and 4 for formatting and codes in respective operational guidance.

C Codes					
C <sub>0</sub> Ocean region code (when required)	C <sub>1</sub> Priority code	C <sub>2</sub> Service code	C <sub>3</sub> Address code	C <sub>4</sub> Repetition code (see annex 2, part E)	C <sub>5</sub> Presentation code
1-digit code	1-digit code	2-digit code	2, 4, 10 or 12 alphanumeric code	2-digit code	1- or 2-digit code
0 – AOR-W 1 – AOR-E 2 – POR 3 – IOR 9 – All ocean regions*	1 – Safety 2 – Urgency 3 – Distress	00 – All ships (general call) 04 – Navigational, meteorological or piracy warning or meteorological forecast to a rectangular area 13 – Navigational, meteorological, coastal or piracy warning or meteorological forecast to a coastal warning area 14 – Shore-to-ship distress alert to a circular area 24 – Navigational, meteorological or piracy warning or meteorological forecast to a circular area 31 – NAVAREA/METAREA, or piracy warning, or meteorological forecast to a NAVAREA/METAREA 34 – SAR coordination to a rectangular area 44 – SAR coordination to a circular area	2 digit – 00 (All ships) 12 alphanumeric rectangular area address D <sub>1</sub> D <sub>2</sub> N(S) D <sub>3</sub> D <sub>4</sub> D <sub>5</sub> E(W) D <sub>6</sub> D <sub>7</sub> D <sub>8</sub> D <sub>9</sub> D <sub>10</sub> 4 alphanumeric coastal warning area address X <sub>1</sub> X <sub>2</sub> B <sub>1</sub> B <sub>2</sub> 10 alphanumeric circular area address D <sub>1</sub> D <sub>2</sub> N(S)D <sub>3</sub> D <sub>4</sub> D <sub>5</sub> E(W) M <sub>1</sub> M <sub>2</sub> M <sub>3</sub> 10 alphanumeric circular area address D <sub>1</sub> D <sub>2</sub> N(S)D <sub>3</sub> D <sub>4</sub> D <sub>5</sub> E(W) M <sub>1</sub> M <sub>2</sub> M <sub>3</sub> 2 digit – NAVAREA/METAREA number 12 alphanumeric rectangular area address D <sub>1</sub> D <sub>2</sub> N(S) D <sub>3</sub> D <sub>4</sub> D <sub>5</sub> E(W) D <sub>6</sub> D <sub>7</sub> D <sub>8</sub> D <sub>9</sub> D <sub>10</sub> 10 alphanumeric circular area address D <sub>1</sub> D <sub>2</sub> N(S)D <sub>3</sub> D <sub>4</sub> D <sub>5</sub> E(W) M <sub>1</sub> M <sub>2</sub> M <sub>3</sub>	Category (a) – for EGC messages to be repeated a finite number of times. Category (b) – for EGC messages to be repeated at specified intervals until cancelled by the information provider.	Always 0** or 00

\* Subject to availability through LES or service provider.

\*\* Value of the presentation code is given by the LES operator or service provider after registration.

**8.2** The syntax of the special address header in relation to the exact number of digits and/or alphanumeric characters, and to the spaces between each C code, is critical and must conform to the format required by LES or service provider used.

**8.3** SafetyNET messages are stored at the addressed LES until transmitted the appropriate number of times, as specified by the C<sub>4</sub> code, although the information provider may also cancel a message at any time by sending an appropriate cancellation message to LES.

**8.4** Cancellation procedure may vary between different LESs or service providers. A detailed operational procedure is contained in the instructions on sending EGC broadcast given to the information providers after registration with the LES operator or service providers.

**8.5** Messages destined for areas of satellite overlap that are required to be transmitted through more than one satellite, should be sent to more than one LES (i.e. one in each *satellite ocean region*) or multiple ocean regions via the same LES to ensure they are received by all intended ships. This may require coordination

with adjacent NAVAREA/METAREA and other information providers. In an area of overlap coverage from two or three ocean region satellites, distress alert relays and urgency warnings will be broadcast over all satellites which cover the affected region.

**8.6** Scheduled broadcasts are made over nominated satellites and at specified times, as allocated by the IMO EGC Coordinating Panel. These schedules are published in national nautical publications and the IMO Master Plan of shore-based facilities for the GMDSS.

**8.7** MSI providers should adhere to their published scheduled broadcast times to facilitate reception of messages.

## 9 Monitoring of MSI- and SAR-related broadcasts\*

**9.1** In order to ensure the integrity of the MSI- and SAR-related messages being broadcast, information providers should monitor the broadcasts which they originate in accordance with resolutions A.706(17), as amended, and A.1051(27), as amended, and COMSAR/Circ.37. Monitoring is especially important in a highly automated system, which is dependent on careful adherence to procedure and format. This should be accomplished by the installation of a type-approved Inmarsat EGC receiver to enable each MSI and SAR information provider to:

- .1 confirm that the message is transmitted and received correctly;
- .2 ensure that cancellation messages are properly executed; and
- .3 observe any unexplained delay in the message being broadcast.

**9.2** Inmarsat SES only display or print messages on the first occasion they are received. Therefore, in order for MSI and SAR information providers to confirm that all messages in force are still being transmitted by the SafetyNET services, and that cancelled messages are no longer being transmitted, the Inmarsat SES used by the MSI and SAR information provider to monitor their broadcast should be powered down (including the transceiver), and rebooted at regular intervals, wherever this is possible. Alternatively, MSI and SAR information providers should consult their equipment supplier for specialist EGC monitoring software which would not require the Inmarsat SES to be rebooted.

**9.3** All Inmarsat SES capable of receiving MSI- and SAR-related information maintain a log, which contains information on all SafetyNET services messages received by the terminal.

This information within the log includes:

Message number	Generated by the terminal
LES or network	ID of the unique originator which transmits the message
Service	The SES software translates the C <sub>2</sub> service code used in the message address and displays a short title for the particular type message service.
Priority	The SES software translates the C <sub>1</sub> priority code used in the message address and displays the appropriate Priority. This could be either: Safety, Urgency or Distress.
Received date and time	The date time group YY-MM-DD HH:mm of when the message was received. A format of the date is configurable by the SES operator.
Size	Usually in number of bytes or characters.
Sequence number	The unique message sequence or reference number allocated to the message by the addressed LES or network.
Routeing	Message routeing (memory or memory and printer) – set up by the SES operator or a mandatory routeing for Urgency and Distress priority messages.

\* Monitoring of MSI and SAR broadcasts in a multi-provider environment is currently under discussion within the relevant IMO, IHO, WMO, MSI and SAR bodies.



**Table 1:** Example of an EGC SafetyNET Log

Message number	LES	Service	Priority	Received date and time	Size	Sequence number	Routeing
20022405.egc	321	MET/NAV warning/forecast	Safety	20-02-24 03:31	2263	1605	Mem
20022402.egc	321	SAR coordination	Urgency	20-02-24 03:02	1506	1604	Prn+Mem
20022401.egc	322	Coastal warning/forecast	Safety	20-02-23 02:56	269	9154	Mem
20022302.egc	304	Distress alert relay	Distress	20-02-23 20:44	769	691	Prn+Mem
20022305.egc	317	NAV warning	Safety	20-02-23 19:41	819	8318	Mem
20022302.egc	322	MET warning	Safety	20-02-23 19:35	2358	9150	Mem

## 10 Accessing SafetyNET services

**10.1** MSI- and SAR-related information is transmitted to LESs providing Inmarsat EGC services in accordance with national and international routeing arrangements. Access to different LESs may require use of different user interfaces that may have different access procedures and syntax commands and it should be checked with the Inmarsat C LES operator or service provider.

**10.2** Some LESs may provide email, or internet (direct) drop access to the SafetyNET service that allows registered MSI- and SAR-related information providers to send information using email from any computer with internet. Due to the nature of the internet, an email service may not guarantee that the information will be received by the addressed LES without delay and may not support cancellation procedures. For this reason, monitoring of all MSI- and SAR-related information is especially important in accordance with section 9 above.

**10.3** For accessing the SafetyNET II service, see annex 4.

## 11 Land earth station functions

**11.1** Messages for transmission via the SafetyNET services are received and processed automatically at LES. Because the system is automatic, the quality of service and information depends on accurate preparation of messages.

**11.2** Messages are not reviewed for corruption or accuracy at LES; therefore, the originator should take special care to adhere to the format specified. This dependence on syntax is one of the reasons why MSI- and SAR-related information providers should monitor the broadcasts they originate.

**11.3** Participating LESs transmit SafetyNET messages over an inter-station signalling link to the ocean region network coordination station (NCS) in the relevant ocean region for transmission over the broadcast channel.

**11.4** Messages will be queued at LES and scheduled for transmission according to priority and instructions contained in the special address headers ( $C_1$  – priority code and  $C_4$  – repetition code); messages with the highest priority will be transmitted first (i.e. in the order “distress”, “urgency”, “safety”). The originator of each message will specify in the address field the desired number of repetitions and the interval between transmissions for that message.

## 12 Receiving SafetyNET services broadcasts

**12.1** The basic requirements of the Inmarsat SES are that it should continuously receive the broadcast channel and process the messages being transmitted through the satellite. However, certain classes of receiving equipment may not provide wholly uninterrupted monitoring of the broadcast channel, for example, if the receiver was tuned to an LES messaging channel to receive or transmit a message and initial broadcast was

missed. For this reason, information providers should repeat their most important **unscheduled messages** 6 minutes after the first broadcast so that the terminal would receive the information on the repeated broadcast.

**12.2** Although the Inmarsat SES receives all SafetyNET messages on the broadcast channel, it may suppress some messages from being displayed or printed automatically. For example:

- .1 all messages addressed to geographical areas (circular or rectangular) other than those including the ship's current position will be automatically suppressed;
- .2 for coastal warnings only (see figure 9) it may be programmed to suppress:
  - .1 messages containing B<sub>1</sub> codes for coastal warning areas which have not been set up in the terminal; and
  - .2 messages containing B<sub>2</sub> codes for subject matter of no relevance to the ship.

**12.3** The Inmarsat SES also suppresses the printing of messages previously received. It is not possible to reject mandatory "all ship" messages such as shore-to-ship distress alert relays for the area within which the ship is located. When a distress or urgency message is received, an audio and visual alarm will be given.

**12.4** The following B<sub>2</sub> code subject indicators for coastal warnings are in use:\*

A	= Navigational warnings*	I	= not used
B	= Meteorological warnings*	J	= SATNAV messages
C	= Ice reports	K	= Other electronic navaid messages
D	= Search and rescue information, and acts of piracy warnings*	L	= Other navigational warnings – additional to B <sub>2</sub> code A
E	= Meteorological forecasts*	V	} Special services allocation by the International EGC Coordinating Panel
F	= Pilot service messages	W	
G	= AIS	X	
H	= LORAN messages	Y	
		Z	= No messages on hand

**12.5** It is recommended that, in order to ensure that all necessary MSI is available before sailing, the Inmarsat SES should remain in operation while the ship is in port.

**12.6** Although reception of MSI- and SAR-related information is automatic, the shipboard operator must set up the Inmarsat SES properly before the start of the voyage in accordance with manufacturer's instructions.

**12.7** The position information in Inmarsat SESs is updated automatically from integrated navigational receivers and they are fitted on all modern (latest) terminals, or may be updated from a separate electronic position-fixing system. If there is no automatic position update system installed, e.g. on older Inmarsat SES terminals, it is recommended that the position in the Inmarsat SES is updated at least every 4 hours. If the position has not been updated for more than 12 hours or is unknown, all SafetyNET messages within the entire satellite ocean region will be printed or stored in the Inmarsat SES.

**12.8** The majority of Inmarsat C SES terminals with EGC reception capability are Class 2 Inmarsat C terminals. MSI- and SAR-related information broadcasts will only be received when the terminal is idle. Therefore, Class 2 terminals should not be in use for other communications at the times of scheduled broadcasts. Similarly, in the case of Class 3 Inmarsat C SES (having two separate receivers for Inmarsat C messages, MSI- and SAR-related information), it is necessary to ensure that it is tuned to the broadcast channel of the appropriate satellite at the times of scheduled broadcasts.

**Note:** More information on different classes of Inmarsat C and mini-C SESs is contained in annex 3.

\* Cannot be rejected by the receiver.

### **13 Charges for SafetyNET services**

**13.1** Resolution A.707(17) on *Charges for Distress, Urgency and Safety Messages Through the Inmarsat System* establishes the arrangements in place for the treatment of charges.

**13.2** There are no charges to the mariner for reception of SafetyNET messages.

**13.3** Message transmission charges apply to information providers and are set at a special SafetyNET tariff by national telecommunication service providers and LESs offering EGC services

## Annex 1

### The Inmarsat system

#### 1 Introduction

1.1 There are three essential components of the Inmarsat system:

- .1 Inmarsat space segment – the satellites and their ground support facilities – planned and funded by Inmarsat;
- .2 ground segment – comprises a network of land earth stations (LEs), network coordination stations (NCSs) and the network operations centre (NOC). Each LES provides an interface between the space segment and the national and international fixed telecommunication networks; and
- .3 ship earth stations (SEs) – comprise mobile satellite communication terminals.

#### 2 Bandwidths

Shore-to-ship communications are in the 6 GHz band (C-band) from LES to the satellite and in the 1.5 GHz band (L-band) from satellite to ship. Ship-to-shore communications are in the 1.6 GHz band (L-band) from the ship to the satellite and in the 4 GHz band (C-band) from satellite to LES.

#### 3 The space segment

3.1 To provide the space segment for global coverage, Inmarsat employs its own dedicated satellites.

**Table 1-1: Inmarsat space segment and relevant ship earth stations**

Satellite	Inmarsat C ocean region	Fleet Safety ocean region	Ship earth stations
3-F5	AOR-E (Atlantic Ocean region east)		Inmarsat C & mini-C
4-F3	AOR-W (Atlantic Ocean region west)	AMER (Americas)	Inmarsat C, mini-C & Fleet Safety
4-F1	POR (Pacific Ocean region)	APAC (Asian Pacific)	Inmarsat C, mini-C & Fleet Safety
4-F4	IOR (Indian Ocean region)	EMEA (Europe Middle East & Africa)	Inmarsat C, mini-C & Fleet Safety
4-F2		MEAS (Middle East & Asia)	Fleet Safety

3.2 The space segment is segmented globally into four ocean regions: Atlantic Ocean region east (AOR-E), Atlantic Ocean region west (AOR-W), Indian Ocean region (IOR) and Pacific Ocean region (POR). Each ocean region is served by a dedicated satellite. Inmarsat has full contingency plans in place in the unlikely event of any prime satellite outage. These plans are exercised regularly and are witnessed by the International Mobile Satellite Organization (IMSO). The polar regions – above approximate latitudes 76°N and 76°S – cannot be seen by geostationary satellites (see figures 3, 4, 5 and 6).

#### 4 The ground segment

4.1 The Inmarsat system is connected into the worldwide telecommunication networks via LESs. Many of these LESs provide Inmarsat C EGC services.

**4.2** For the Inmarsat C communication system there is an NCS in each ocean region, which monitors and controls communications traffic within its region. Each NCS communicates with the LESs in its ocean region, the other NCSs and the NOC. Inmarsat C NCSs also transmit EGC SafetyNET messages on the NCS common channel.

**4.3** NOC is located in London at Inmarsat headquarters and functions around the clock, coordinating the activities of NCSs and LESs in each ocean region.

## **5 Ship earth stations**

**5.1** Inmarsat C and mini-C SESs with the EGC function are small, lightweight terminals, with small omni-directional antennas, for providing data and message-type services. EGC receive capability is provided by Class 2 or 3 Inmarsat C SESs. Interfaces via RS232 ports are provided for a dedicated messaging unit, personal computer or any other data terminal equipment for message generation and display.

**5.2** Class 0 stand-alone EGC receivers provide the capability to receive SafetyNET messages only; there is no transmit or receive capability for sending and receiving messages.

**5.3** The technical requirements of all classes of equipment are detailed in annex 3.

## Annex 2

### *Operational guidance for SafetyNET services*

1 This annex contains operational guidance for the benefit of registered information providers who are responsible for preparing messages for broadcast via SafetyNET services. See annex 4 for SafetyNET II and RescueNET.

**Use of the codes given in this annex is mandatory for all messages in the system.**

2 Types of messages and message formats are detailed in the sub-parts of this annex.

Part A – Navigational warning services

Part B – Meteorological services

Part C – Search and rescue (SAR) services and SAR coordination traffic

Part D – Piracy countermeasures broadcast messages

Part E – Repetition codes (C<sub>4</sub>)

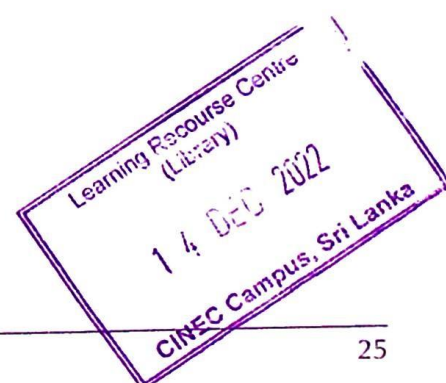

Allocation of priority and service codes for EGC SafetyNET services		
EGC SafetyNET services	Message priority	Service code (type)
Navigational warning services	C <sub>1</sub> = 1 (Safety) – normally	C <sub>2</sub> = 04 – Navigational warning to a rectangular area
	C <sub>1</sub> = 2 (Urgency) – exceptionally at discretion of information provider	C <sub>2</sub> = 13 – Coastal warning to a coastal warning area
		C <sub>2</sub> = 24 – Navigational warning to a circular area
		C <sub>2</sub> = 31 – NAVAREA warning to a NAVAREA
Meteorological services	C <sub>1</sub> = 1 (Safety) – always for forecasts and warnings	C <sub>2</sub> = 04 – Meteorological warning or forecast to a rectangular area
	C <sub>1</sub> = 2 (Urgency) – always for Beaufort Force 12 and above warnings only	C <sub>2</sub> = 13 – Meteorological warning or forecast to a coastal warning area
		C <sub>2</sub> = 24 – Meteorological warning or forecast to a circular area
		C <sub>2</sub> = 31 – Meteorological warning or forecast to a METAREA
SAR services:	C <sub>1</sub> = 3 (Distress) – always	C <sub>2</sub> = 14 – Shore-to-ship distress alert to a circular area
1) shore-to-ship distress alert		
2) SAR coordination traffic	C <sub>1</sub> = 1 (Safety) – determined by the phase of emergency	C <sub>2</sub> = 34 – SAR coordination to a rectangular area
	C <sub>1</sub> = 2 (Urgency) – determined by the phase of emergency	C <sub>2</sub> = 44 – SAR coordination to a circular area
	C <sub>1</sub> = 3 (Distress) – determined by the phase of emergency	
3) shore-to-ship urgency and safety traffic	C <sub>1</sub> = 1 (Safety) C <sub>1</sub> = 2 (Urgency)	C <sub>2</sub> = 31 – Urgency and safety traffic
4) general (all ships call within the Inmarsat ocean region)	C <sub>1</sub> = 2 (Urgency)	C <sub>2</sub> = 00
	C <sub>1</sub> = 3 (Distress)	
Piracy countermeasures broadcast messages	C <sub>1</sub> = 1 (Safety)	C <sub>2</sub> = 04 – Piracy warning to a rectangular area
	C <sub>1</sub> = 2 (Urgency) – for piracy attack warnings	C <sub>2</sub> = 13 – Piracy warning to a coastal warning area
		C <sub>2</sub> = 24 – Piracy warning to a circular area
		C <sub>2</sub> = 31 – Piracy warning to a NAVAREA

3 The broadcast parameters are controlled by the use of five (or six) C codes which are combined into a generalized message address header format as follows:

$$C_0:C_1:C_2:C_3:C_4:C_5$$

(Spaces, colons or other delimiters between these codes will be required, depending on the communication protocol of the addressed LES)

$C_0$  – Ocean region

$C_1$  – Message priority

$C_2$  – Service code

$C_3$  – Address code

$C_4$  – Repetition code

$C_5$  – Presentation code

Each C code controls a different broadcast parameter and is assigned a numerical value according to the options specified in the following parts.

The additional  $C_0$  code will only be required to identify the satellite ocean region when sending a broadcast message to an LES which operates to more than one satellite ocean region, as follows:

$C_0 = 0$  – AOR-W

$C_0 = 1$  – AOR-E

$C_0 = 2$  – POR

$C_0 = 3$  – IOR

$C_0 = 9$  – All ocean regions\*

4 (a) All EGC messages should comprise three elements:

- Address header instruction (EGC C codes)
- TEXT OF MESSAGE
- NNNN

<b>Mandatory message element table</b>	
<b>Message element</b>	<b>Remarks</b>
Address header instruction	The syntax of the special address header in relation to the exact number of digits and/or alphanumeric characters, and to the spaces between each C code is critical, and must conform to the format required by the LES or service provider as supplied in their specific instruction manual.
TEXT OF MESSAGE	The content of the message should be presented in UPPER case.  For maritime safety information messages, the format of navigational warnings, and meteorological warnings and forecasts is defined in the <i>Joint IMO/IHO/WMO Maritime Safety Information Manual</i> , as amended.
NNNN	The letters NNNN should be inserted at the end of the text to indicate "end of message".

\* Subject to availability through LES or service provider.



- (b) EGC messages submitted for transmission (or broadcast) via a two-stage access system must also include an end of transmission instruction code for the LES. This should be inserted on the final line, after NNNN. This code may vary and must conform to the format required by the LES or service provider as supplied in their specific instruction manual.

5 The International Maritime Organization (IMO) requires that, in order to allow the use of non-dedicated receive facilities, the majority of broadcasts on the International SafetyNET Service are made at scheduled times. Broadcast schedules must be coordinated through the IMO EGC Coordinating Panel, which can also offer advice on ways of scheduling information within the system.

6 Because errors in the header format of a message may prevent it being released, MSI- and SAR-related information providers must install an Inmarsat SafetyNET receiver and monitor broadcasts of messages which they originate.

7 For all the services described below, a cancellation or deleting facility is provided for messages transmitted to an LES with category (b) repetition codes (see part E). Cancellation (or deletion) procedures may vary between different LESs or service providers. Detailed operational procedure is contained in the instructions on sending EGC broadcasts given to the MSI- and SAR-related information providers after registration with the LES operator or service provider.

8 The term “echo” used in all of the services described below in parts A, B, C and D, is associated with using the respective C<sub>4</sub> repetition codes which will initiate an automatic repeated broadcast 6 minutes after the initial scheduled or unscheduled broadcast. The 6-minute repeat or echo is used to ensure that the warning is received by the maximum number of ships.

## Part A – Navigational warning services

1 The following guidelines set out the arrangements to be used for promulgating navigational and coastal warnings via SafetyNET for the GMDSS. They are mandatory for broadcasts in the International SafetyNET Service. Broadcasts originated by the International Ice Patrol also follow the guidelines in this part.

2 These guidelines are to be read in conjunction with the *IMO/IHO Worldwide Navigational Warning Service (WWNWS) Guidance Document* (resolution A.706(17), as amended).

3 Navigational warnings that require an immediate broadcast should be transmitted as soon as possible after receipt. If still in force, they should be repeated in subsequent scheduled broadcasts, twice a day for 6 weeks or until cancelled.

4 Navigational warnings should remain in force until cancelled by the originating coordinator. Navigational warnings should be broadcast for as long as the information is valid; however, if they are readily available to mariners by other official means, for example in Notices to Mariners, then after a period of 6 weeks they may no longer be broadcast. If the navigational warning is still valid and not available by other means after 6 weeks, it should be re-issued as a new navigational warning.

5 The following C codes should be used for warnings issued under the auspices of the WWNWS.

### 5.1 C<sub>1</sub> – Message priority

C<sub>1</sub> = 1 (safety)

C<sub>1</sub> = 2 (urgency) (at discretion of the registered information provider)

## 5.2 C<sub>2</sub> – Service code\*

C <sub>2</sub> = 04	Navigational warning to a rectangular area*
C <sub>2</sub> = 13	Coastal warning to a coastal warning area
C <sub>2</sub> = 24	Navigational warning to a circular area
C <sub>2</sub> = 31	NAVAREA warning to a NAVAREA

## 5.3 C<sub>3</sub> – Address code

C <sub>3</sub> = two digits X <sub>1</sub> X <sub>2</sub>	When C <sub>2</sub> = 31, then: X <sub>1</sub> X <sub>2</sub> are the two digits of the NAVAREA number (with a leading zero where necessary in the range 01 – 21).
C <sub>3</sub> = four alphanumeric characters X <sub>1</sub> X <sub>2</sub> B <sub>1</sub> B <sub>2</sub>	When C <sub>2</sub> = 13 for coastal warnings, then: X <sub>1</sub> X <sub>2</sub> are the two digits of the NAVAREA number (with a leading zero where necessary in the range 01 – 21) B <sub>1</sub> is the coastal warning area A to Z B <sub>2</sub> is the subject indicator and must always be A or L, where: A = Navigational warnings L = Other navigational warnings
C <sub>3</sub> = twelve alphanumeric characters D <sub>1</sub> D <sub>2</sub> LaD <sub>3</sub> D <sub>4</sub> D <sub>5</sub> LoD <sub>6</sub> D <sub>7</sub> D <sub>8</sub> D <sub>9</sub> D <sub>10</sub>	When C <sub>2</sub> = 04 for NAVAREA warnings within a rectangular area: D <sub>1</sub> D <sub>2</sub> is latitude of south-west corner of the rectangle in degrees La is hemisphere which will always be N for Arctic NAVAREAs XVII to XXI D <sub>3</sub> D <sub>4</sub> D <sub>5</sub> is longitude of south-west corner of rectangle in degrees, with leading zeros if required Lo is longitude E or W D <sub>6</sub> D <sub>7</sub> is extent of rectangle in latitude (degrees) D <sub>8</sub> D <sub>9</sub> D <sub>10</sub> is extent of rectangle in longitude (degrees)
<b>Example:</b> a rectangle whose south-west corner is 60°N and 010°W, extending 30° north and 25° east, is coded as: 60N010W30025	
<b>Note:</b> Latitude and longitude are limited by values from 00° to 90° latitude and 000° to 180° longitude.	

\* Until Inmarsat C or mini-C terminals operating in arctic waters have been updated or replaced, C<sub>2</sub> = 04 may be used for NAVAREA warnings to a rectangular area by NAVAREAs XVII, XVIII, XIX, XX and XXI.

#### 5.4 C<sub>4</sub> – Repetition code

C <sub>4</sub> = 01	May be used for initial unscheduled broadcast of NAVAREA warnings, and coastal warnings with no echo (transmit once on receipt)
C <sub>4</sub> = 11	Recommended for use with initial unscheduled broadcast of NAVAREA warnings, and coastal warnings (transmit on receipt, echo 6 minutes later)
C <sub>4</sub> = 16	Use for NAVAREA or coastal warnings scheduled for broadcast twice per day at 12-hour intervals with safety priority

**Note:** For NAVAREA or coastal warnings scheduled for broadcast more than twice per day, the appropriate C<sub>4</sub> repetition code detailed in part E of this Manual must be used.

#### 5.5 C<sub>5</sub> – Presentation code

C <sub>5</sub> = 00	The code 00 for International Alphabet Number 5 is normally used
---------------------	--

### Part B – Meteorological services

1 The following guidelines set out the arrangements to be used for promulgating meteorological forecasts and warnings via SafetyNET for the GMDSS. They are mandatory for broadcasts in the International SafetyNET Service.

2 These guidelines are to be read in conjunction with the *IMO/WMO Worldwide MET-Ocean Information and Warning Service (WMMIWS) Guidance Document* (resolution A.1051(27), as amended) and in conjunction with the *WMO Manual on Marine Meteorological Services* (WMO No.558), as amended.

3 In order to ensure uniformity of meteorological forecasts and warnings globally, the following C codes should be used for meteorological services via SafetyNET.

#### 3.1 C<sub>1</sub> – Message priority

C <sub>1</sub> = 2 (urgency)	Only use for meteorological warnings with Beaufort Force 12 or above
C <sub>1</sub> = 1 (safety)	For forecasts and other meteorological warnings

#### 3.2 C<sub>2</sub> – Service code\*

C <sub>2</sub> = 04	Meteorological warning or forecast to a rectangular area
C <sub>2</sub> = 13	Meteorological warning or forecast to a coastal warning area
C <sub>2</sub> = 24	Meteorological warning or forecast to a circular area
C <sub>2</sub> = 31	Meteorological warning or forecast to a METAREA

\* Until Inmarsat C or mini-C terminals operating in arctic waters have been updated or replaced, C<sub>2</sub> = 04 may be used for METAREA warnings or meteorological forecasts to a rectangular area by METAREAs XVII, XVIII, XIX, XX and XXI.

3.3 C<sub>3</sub> – Address code

<p>C<sub>3</sub> = ten alphanumeric characters D<sub>1</sub>D<sub>2</sub>LaD<sub>3</sub>D<sub>4</sub>D<sub>5</sub>LoR<sub>1</sub>R<sub>2</sub>R<sub>3</sub></p>	<p>When C<sub>2</sub> = 24 for meteorological warnings to user-defined circular area, then:</p> <p>D<sub>1</sub>D<sub>2</sub>La (three characters) is latitude of centre in degrees, and La whether north (N) or south (S). A leading zero should be used for latitudes less than 10°</p> <p>D<sub>3</sub>D<sub>4</sub>D<sub>5</sub>Lo (four characters) is longitude of centre in degrees, and Lo whether east (E) or west (W) of the prime meridian. One or two leading zeros should be used for longitudes less than 100°</p> <p>R<sub>1</sub>R<sub>2</sub>R<sub>3</sub> (three characters) is radius of circle in nautical miles, up to 999. One or two leading zeros should be used for radius less than 100 nm</p>
<p><b>Example:</b> A circle centred at latitude 26°S longitude 54°W with radius of 70 nautical miles is coded as: 26S054W070</p>	
<p>C<sub>3</sub> = two digits XX</p>	<p>When C<sub>2</sub> = 31, for meteorological warnings or forecasts to a METAREA then:</p> <p>C<sub>3</sub> = the two digits of the METAREA number (with a leading zero where necessary in the range 01 – 21)</p>
<p>C<sub>3</sub> = four alphanumeric characters X<sub>1</sub>X<sub>2</sub>B<sub>1</sub>B<sub>2</sub></p>	<p>When C<sub>2</sub> = 13 for meteorological warnings or forecasts to available pre-defined coastal warning areas, then:</p> <p>X<sub>1</sub>X<sub>2</sub> are the two digits of the METAREA number (with a leading zero where necessary in the range 01 – 21)</p> <p>B<sub>1</sub> is the coastal warning area A to Z</p> <p>B<sub>2</sub> is the subject indicator and must always be B or E, where:</p> <p style="padding-left: 40px;">B = Meteorological warnings</p> <p style="padding-left: 40px;">E = Meteorological forecasts</p>
<p>C<sub>3</sub> = twelve alphanumeric characters D<sub>1</sub>D<sub>2</sub>LaD<sub>3</sub>D<sub>4</sub>D<sub>5</sub>LoD<sub>6</sub>D<sub>7</sub>D<sub>8</sub>D<sub>9</sub>D<sub>10</sub></p>	<p>When C<sub>2</sub> = 04 for meteorological warnings or forecasts within a rectangular area</p> <p>D<sub>1</sub>D<sub>2</sub> is latitude of south-west corner of the rectangle in degrees</p> <p>La is hemisphere N or S</p> <p>D<sub>3</sub>D<sub>4</sub>D<sub>5</sub> is longitude of south-west corner of rectangle in degrees, with leading zeros if required</p> <p>Lo is longitude E or W</p> <p>D<sub>6</sub>D<sub>7</sub> is extent of rectangle in latitude (degrees)</p> <p>D<sub>8</sub>D<sub>9</sub>D<sub>10</sub> is extent of rectangle in longitude (degrees)</p>
<p><b>Example:</b> To cover Arctic METAREA XVIII, use a rectangle whose south-west corner is 67°N and 120°W, extending 23° north and 85° east, coded as: 67N120W23085</p>	
<p><b>Note:</b> Latitude and longitude are limited by values from 00° to 90° latitude and 000° to 180° longitude.</p>	

### 3.4 C<sub>4</sub> – Repetition code

Category (a) repetition codes are used for meteorological services as follows:

C <sub>4</sub> = 01	Use for meteorological forecast (transmit once on receipt)
C <sub>4</sub> = 11	Use for meteorological warning (transmit on receipt followed by repeat 6 minutes later)

### 3.5 C<sub>5</sub> – Presentation code

C <sub>5</sub> = 00	The code 00 for International Alphabet Number 5 is normally used
---------------------	--

## Part C – Search and rescue services and SAR coordination traffic

1 The following guidelines set out the arrangements to be used by rescue coordination centres (RCCs) for initiating transmission of shore-to-ship distress alert relays and shore-to-ship SAR-related information. Transmissions should be in accordance with the relevant procedures of the International Telecommunication Union (ITU) Radio Regulations (RR), the International Convention on Maritime Search and Rescue, 1979, as amended, and the International Aeronautical and Maritime Search and Rescue (IAMSAR) Manual.

2 In order to ensure uniformity of the SAR broadcast product throughout the world, C codes should be used as described in this part.

### 3 Shore-to-ship distress alert relays

3.1 As a general principle, distress alert relays should be addressed to a circular area around the estimated or known position of the distressed vessel. The radius of the circle should be chosen to take account of the accuracy of the datum position, the expected density of shipping in the vicinity and the fact that the position can only be defined in the message address to the nearest whole degree of latitude and longitude. The distress alert relay message must be broadcast via all satellites which cover the area concerned. Shore-to-ship distress alert relays sent by the International SafetyNET Service should contain the identification of the unit in distress, its approximate position and other information which might facilitate rescue. C codes should be as follows:

#### 3.2 C<sub>1</sub> – Message priority

C <sub>1</sub> = 3 (distress)
-------------------------------

#### 3.3 C<sub>2</sub> – Service code

C <sub>2</sub> = 14 (shore-to-ship distress alert to circular areas)	Messages addressed to circular areas will only be received and printed out by EGC receivers that are located inside the circle or have not had their position kept up to date
---	---

### 3.4 C<sub>3</sub> – Address code

<p>C<sub>3</sub> = ten alphanumeric characters D<sub>1</sub>D<sub>2</sub>LaD<sub>3</sub>D<sub>4</sub>D<sub>5</sub>LoR<sub>1</sub>R<sub>2</sub>R<sub>3</sub></p>	<p>When C<sub>2</sub> = 14 for distress alert to user defined circular area, then:</p> <p>D<sub>1</sub>D<sub>2</sub>La (three characters) is latitude of vessel in distress in degrees (two digits) and whether north (N) or south (S): e.g. 39N (three characters total). A leading zero should be included for latitudes less than 10°</p> <p>D<sub>3</sub>D<sub>4</sub>D<sub>5</sub>Lo (four characters) is longitude of vessel in distress in degrees (three digits) and whether east (E) or west (W) of the prime meridian: e.g. 059W. A leading zero or zeros should be included for longitudes less than 100° or 10° as appropriate: e.g. use 099 for 99° and 008 for 8°</p> <p>R<sub>1</sub>R<sub>2</sub>R<sub>3</sub> (three characters) is alert radius around distressed vessel in nautical miles. To ensure that position inaccuracies of both the distressed vessel and nearby vessels to which the message is intended do not affect receipt of messages, radius values of 200 nautical miles or larger should normally be used. Note that if a vessel's own position information is not entered into its SafetyNET receiver, every shore-to-ship distress alert relay message transmitted to the Inmarsat ocean region will be received and printed</p>
---	--

### 3.5 C<sub>4</sub> – Repetition code

C <sub>4</sub> = 11	Use for distress alerts (transmit on receipt followed by repeat 6 minutes later)
---------------------	--

### 3.6 C<sub>5</sub> – Presentation code

C <sub>5</sub> = 00	The code 00 for International Alphabet Number 5 is normally used
---------------------	--

## 4 General (all ships) call

4.1 When the RCC has no indication of the position of the vessel in distress, shore-to-ship distress alert relays may be sent as general call. This will be printed in every vessel within the Inmarsat ocean region, provided the receiver is tuned to the proper ocean region satellite.

**Note:** This method of alert should rarely be used.

The C<sub>0</sub>:C<sub>1</sub>:C<sub>2</sub>:C<sub>3</sub>:C<sub>4</sub>:C<sub>5</sub> codes for general calls are always as follows:

C<sub>0</sub> = 0 (1, 2 or 3) (if required)

C<sub>1</sub> = 3 (distress) or 2 (urgency)

C<sub>2</sub> = 00

C<sub>3</sub> = 00

C<sub>4</sub> = 11

C<sub>5</sub> = 00

## 5 Search and rescue coordination traffic

5.1 SAR coordination messages should be addressed to user-defined circular or rectangular areas for the intent of coordinating the search and rescue of a vessel in distress. Priority of the message will be determined by the phase of the emergency.

### 5.2 C<sub>1</sub> – Message priority

C <sub>1</sub> = 3 (distress), 2 (urgency) or 1 (safety)
--

### 5.3 C<sub>2</sub> – Service code

C <sub>2</sub> = 34	Search and rescue coordination to a rectangular area
C <sub>2</sub> = 44	Search and rescue coordination to a circular area

### 5.4 C<sub>3</sub> – Address code

C <sub>3</sub> = twelve alphanumeric characters D <sub>1</sub> D <sub>2</sub> LaD <sub>3</sub> D <sub>4</sub> D <sub>5</sub> LoD <sub>6</sub> D <sub>7</sub> D <sub>8</sub> D <sub>9</sub> D <sub>10</sub>	When C <sub>2</sub> = 34 Search and rescue coordination to a rectangular area  <b>Note:</b> The definition of 12 characters for a rectangular address is given in part A, paragraph 5.3
C <sub>3</sub> = ten alphanumeric characters D <sub>1</sub> D <sub>2</sub> LaD <sub>3</sub> D <sub>4</sub> D <sub>5</sub> LoR <sub>1</sub> R <sub>2</sub> R <sub>3</sub>	When C <sub>2</sub> = 44 search and rescue coordination to a circular area  <b>Note:</b> The definition of 10 characters for a circular address is given in part B, paragraph 3.3

### 5.5 C<sub>4</sub> – Repetition code

C <sub>4</sub> = 11	Use for distress alerts (transmit on receipt followed by repeat 6 minutes later)
---------------------	--

### 5.6 C<sub>5</sub> – Presentation code

C <sub>5</sub> = 00	The code 00 for International Alphabet Number 5 is normally used
---------------------	--

## 6 Shore-to-ship urgency and safety traffic

6.1 As a general principle, only the minimum information consistent with the safety of navigation should be broadcast. However, where such information is deemed essential, shore-to-ship information other than distress alert relays should be broadcast to a NAVAREA using C codes as follows:

### 6.2 C<sub>1</sub> – Message priority

C <sub>1</sub> = 2 (urgency) or 1 (safety)
--

### 6.3 C<sub>2</sub> – Service code

C <sub>2</sub> = 31
---------------------

**6.4 C<sub>3</sub> – Address code**

C <sub>3</sub> = two digits X <sub>1</sub> X <sub>2</sub>	When C <sub>2</sub> = 31, then: X <sub>1</sub> X <sub>2</sub> are the two digits of the NAVAREA number (with a leading zero where necessary in the range 01–21)
---	--

**6.5 C<sub>4</sub> – Repetition code**

C <sub>4</sub> = 11	Use for unscheduled broadcasts of urgency and safety traffic (transmit on receipt followed by repeat 6 minutes later)
---------------------	---

**6.6 C<sub>5</sub> – Presentation code**

C <sub>5</sub> = 00	The code 00 for International Alphabet Number 5 is normally used
---------------------	--

**7 SAR broadcast for overlapping satellite ocean region**

7.1 SAR distress and urgency broadcasts should be promulgated through all Inmarsat satellites serving the area surrounding the vessel in distress. This is to ensure that vessels with receivers tuned to any ocean region satellite serving the area will receive the message.

**Part D – Piracy countermeasures broadcast messages**

1 On receiving a message of alert or any other information concerning a threat of attack (from the Security Forces Authority responsible for the operational application of the urgency plans (countermeasures) in the region or another RCC, for example), the RCC should ask the NAVAREA coordinator (or any other competent authority in accordance with local arrangements), to send out a warning through the appropriate MSI network (NAVTEX or SafetyNET) and other broadcasting networks for warnings to shipping, if these exist.

2 There are two kinds of MSI messages promulgated with respect to piracy countermeasures: the daily situation report (SITREP) and a piracy attack warning. Specific guidance on drafting and broadcasting these messages is given below.

3 The daily situation report should be broadcast via SafetyNET at a regular time around 0800 local time daily. The following paragraphs provide specific guidance on broadcast procedures.

4 The daily situation report should be broadcast to a rectangular area enclosing the region of probable piracy attacks (based on historical data) plus a margin of 700 nautical miles (24 hours steaming by a fast ship) in every direction.

5 The following C codes illustrate those to be used for SafetyNET broadcasts of the daily SITREP:

**5.1 C<sub>1</sub> – Message priority**

C <sub>1</sub> = 1 (safety)
-----------------------------

**5.2 C<sub>2</sub> – Service code**

C <sub>2</sub> = 04	SITREP to a rectangular area
C <sub>2</sub> = 24	SITREP to a circular area



### 5.3 C<sub>3</sub> – Address code

C <sub>3</sub> = twelve alphanumeric characters D <sub>1</sub> D <sub>2</sub> LaD <sub>3</sub> D <sub>4</sub> D <sub>5</sub> LoD <sub>6</sub> D <sub>7</sub> D <sub>8</sub> D <sub>9</sub> D <sub>10</sub>	When C <sub>2</sub> = 04 SITREP to a rectangular area <b>Note:</b> The definition of 12 characters for a rectangular address is given in part A, paragraph 5.3
C <sub>3</sub> = ten alphanumeric characters D <sub>1</sub> D <sub>2</sub> LaD <sub>3</sub> D <sub>4</sub> D <sub>5</sub> LoR <sub>1</sub> R <sub>2</sub> R <sub>3</sub>	When C <sub>2</sub> = 24 SITREP to a circular area <b>Note:</b> The definition of 10 characters for a circular address is given in part B, paragraph 3.3

### 5.4 C<sub>4</sub> – Repetition code

C <sub>4</sub> = 18	Broadcast every 24 hours (no echo) until cancelled
---------------------	--

### 5.5 C<sub>5</sub> – Presentation code

C <sub>5</sub> = 00	The code 00 for International Alphabet Number 5 is normally used
---------------------	--

6 A piracy attack warning should be broadcast as an “URGENT” NAVAREA or coastal warning immediately on receipt of the source information and at least at the next scheduled broadcast or for as long as the information remains valid. In the area of overlap coverage from two or three ocean region satellites, urgent warnings will be broadcast over all satellites which cover the affected region. Subject indicator character B<sub>2</sub> = L should be used in coastal warning areas. The specific area in which the attack has taken place is to be quoted in the first line of the text, using no more detail than is necessary to indicate the probable location of further attacks, e.g. WESTERN PHILIP CHANNEL or VICINITY HORSBURGH LIGHT. The description of the pirate vessel and its last observed movements are to be kept as brief as possible and should give only those details which are of significance in avoiding other attacks.

7 The following C codes illustrate those to be used for SafetyNET broadcast of piracy attack warnings:

#### 7.1 C<sub>1</sub> – Message priority

C <sub>1</sub> = 2 (urgency)
------------------------------

#### 7.2 C<sub>2</sub> – Service code

C <sub>2</sub> = 13	Coastal warning
C <sub>2</sub> = 31	NAVAREA warning

#### 7.3 C<sub>3</sub> – Address code

C <sub>3</sub> = two digits X <sub>1</sub> X <sub>2</sub>	When C <sub>2</sub> = 31 then: X <sub>1</sub> X <sub>2</sub> are the two digits of the NAVAREA number (with a leading zero where necessary in the range 01 to 21)
---	--

$C_3 =$ four alphanumeric characters $X_1X_2B_1B_2$	When $C_2 = 13$ for coastal warnings then: $X_1X_2$ are the two digits of the NAVAREA number (with a leading zero where necessary in the range 01 to 21) $B_1$ is the coastal warning area A to Z $B_2$ is the subject indicator and must always be A or L, where: A = Navigational warnings L = Other navigational warnings
--	---

#### 7.4 $C_4$ – Repetition code

$C_4 = 16$	Broadcast every 12 hours with no echo until cancelled
------------	---

#### 7.5 $C_5$ – Presentation code

$C_5 = 00$	The code 00 for International Alphabet Number 5 is normally used
------------	--

8 Date/time should always be quoted in the form:

DDHHMM UTC MoMoMo YY

as in the example: 251256 UTC JUN 17

**Note:** UTC (Coordinated Universal Time) is the same time-zone as GMT (Z).

9 Geographical positions should be quoted in the standard format:

$D_1D_2M_1M_2LaD_3D_4D_5M_3M_4Lo$

where:

$D_1D_2$  = degrees latitude (with leading zero if required)

$M_1M_2$  = minutes latitude

La = hemisphere (N or S)

$D_3D_4D_5$  = degrees longitude (with leading zeros if required)

$M_3M_4$  = minutes longitude

Lo = longitude (E or W)

as in the example: 5419N10327E

#### Notes

1 Examples of format and drafting guidance for piracy warnings is contained in the *Joint IMO/IHO/WMO Manual on Maritime Safety Information* (MSC.1/Circ.1310, as amended, and IHO Publication No.S-53).

2 Decimals of minutes will seldom be necessary or appropriate for reports of this kind.

3 Where the name of a geographical feature is used instead of a geographical position, a name should be chosen that appears on all commonly used charts of the area. Local knowledge should not be required for understanding the message.

## Part E – Repetition codes (C<sub>4</sub>)

- 1 The C<sub>4</sub> repetition codes are divided into two categories:
- Category (a) for messages that are required to be repeated a finite number of times; and
  - Category (b) for messages that are required to be repeated at specified intervals until cancelled by the information provider.

### 1.1 Category (a) repetition codes

Code	Instruction
01	transmit once on receipt
11	transmit on receipt followed by repeat 6 minutes later
61	transmit on receipt and 1 hour after initial broadcast (twice)
62	transmit on receipt and 2 hours after initial broadcast (twice)
63	transmit on receipt and 3 hours after initial broadcast (twice)
64	transmit on receipt and 4 hours after initial broadcast (twice)
66	transmit on receipt and 12 hours after initial broadcast (twice)
67	transmit on receipt and 24 hours after initial broadcast (twice)
70	transmit on receipt, 12 hours after initial broadcast and then 12 hours after the second broadcast (three times)
71	transmit on receipt, 24 hours after initial broadcast and then 24 hours after the second broadcast (three times)

### 1.2 Category (b) repetition codes

A category (b) repetition code allows a message to be repeated indefinitely or until cancelled by the message provider. The repetition period can be set at between 1 and 120 hours. In addition, each transmission can be echoed after a fixed period of 6 minutes. Repetition codes are made up by stating the multiplier first, followed by the delay period:

Multiplier × Delay

where the multiplier specifies the amount of delay periods between each broadcast, and the delay is a fixed number of hours. The **multiplier** digit may be any digit from 1 to 5 as follows:

- 1 = 1 specified delay period between broadcasts
- 2 = 2 specified delay periods between broadcasts
- 3 = 3 specified delay periods between broadcasts
- 4 = 4 specified delay periods between broadcasts
- 5 = 5 specified delay periods between broadcasts

The delay digit coding is as follows:

- 2 = 1 hour delay; no echo
- 3 = 1 hour delay; with echo
- 4 = 6 hours delay; no echo
- 5 = 6 hours delay; with echo
- 6 = 12 hours delay; no echo

7 = 12 hours delay; with echo

8 = 24 hours delay; no echo

9 = 24 hours delay; with echo

The various combinations (Multiplier × Delay) available, are shown in the table below:

Code	Instruction
12	repeat broadcast every 1 hour with no echo
13	repeat broadcast every 1 hour with an echo 6 minutes after each broadcast
22	repeat broadcast every 2 hours with no echo
23	repeat broadcast every 2 hours with an echo 6 minutes after each broadcast
32	repeat broadcast every 3 hours with no echo
33	repeat broadcast every 3 hours with an echo 6 minutes after each broadcast
42	repeat broadcast every 4 hours with no echo
43	repeat broadcast every 4 hours with an echo 6 minutes after each broadcast
52	repeat broadcast every 5 hours with no echo
53	repeat broadcast every 5 hours with an echo 6 minutes after each broadcast
14	repeat broadcast every 6 hours with no echo
15	repeat broadcast every 6 hours with an echo 6 minutes after each broadcast
16 (or 24)	repeat broadcast every 12 hours with no echo
17 (or 25)	repeat broadcast every 12 hours with an echo 6 minutes after each broadcast
34	repeat broadcast every 18 hours with no echo
35	repeat broadcast every 18 hours with an echo 6 minutes after each broadcast
18 (or 26; or 44)	repeat broadcast every 24 hours with no echo
19 (or 27; or 45)	repeat broadcast every 24 hours with an echo 6 minutes after each broadcast
54	repeat broadcast every 30 hours with no echo
55	repeat broadcast every 30 hours with an echo 6 minutes after each broadcast
36	repeat broadcast every 36 hours with no echo
37	repeat broadcast every 36 hours with an echo 6 minutes after each broadcast
28 (or 46)	repeat broadcast every 48 hours with no echo
29 (or 47)	repeat broadcast every 48 hours with an echo 6 minutes after each broadcast
56	repeat broadcast every 60 hours with no echo
57	repeat broadcast every 60 hours with an echo 6 minutes after each broadcast
38	repeat broadcast every 72 hours with no echo
39	repeat broadcast every 72 hours with an echo 6 minutes after each broadcast
48	repeat broadcast every 96 hours with no echo
49	repeat broadcast every 96 hours with an echo 6 minutes after each broadcast
58	repeat broadcast every 120 hours with no echo
59	repeat broadcast every 120 hours with an echo 6 minutes after each broadcast

**Note:** Not all codes may be provided by all service providers.





## Annex 3

### *Enhanced group call receiver specifications – Inmarsat C and mini-C*

These technical requirements were defined by Inmarsat for equipment manufacturers and have been extracted from the System Definition Manual (SDM) for the Inmarsat C communications system.

Enhanced group call (EGC) means the broadcast of coordinated maritime safety information and search and rescue related information, to a defined geographical area using a recognized mobile satellite service. EGC receiver facilities are used by SOLAS Convention ships as well as ships not required to comply with the requirements of the SOLAS Convention. It should be noted that EGC receiver facilities intended to meet SOLAS Convention requirements should comply with the *Performance Standards for Enhanced Group Call Equipment* (resolution A.664(16)) or the *Revised Performance Standards for Enhanced Group Call (EGC) Equipment* (resolution MSC.306(87), as amended).

The specific guidance given in this annex has been carefully coordinated to ensure that the automatic functions of the SafetyNET receivers work properly. Land earth stations providing Inmarsat C services for the GMDSS must comply with all relevant aspects of the Inmarsat C SDM, including provision of the EGC SafetyNET services.

### **Technical requirements for enhanced group call receivers for SOLAS-compliant SESs via SafetyNET services**

#### **1 EGC SafetyNET receivers for SOLAS installations**

##### **1.1 Background**

**1.1.1** The Global Maritime Distress and Safety System (GMDSS) is a radiocommunication system based on satellite and terrestrial technology, designed to improve communications relating to distress and safety of life at sea. It was adopted by the International Maritime Organization (IMO) in 1988, in the form of amendments to the International Convention for the Safety of Life at Sea (SOLAS), 1974 and came into effect on 1 February 1992. Implementation was completed on 1 February 1999.

**1.1.2** It is the responsibility of national Administrations to determine whether a radio installation on board a ship meets the SOLAS requirements. This is done by national Type Acceptance or Approval testing of the subsystems included in the installation and by inspection of the complete installation by a radio surveyor.

**1.1.3** National Type Acceptance testing for SOLAS equipment is usually based on GMDSS specifications and procedures prepared by IMO and the International Electrotechnical Commission (IEC) on their behalf, although other national or regional specifications may be invoked as well.

**1.1.4** IMO and IEC documents, which are identified in section 1.2, do not only summarize the general requirements for GMDSS equipment but also the special requirements for EGC SafetyNET receivers for use in SOLAS installations, as specified by IMO/IEC.

**1.1.5** A number of the Inmarsat specifications have been completely revised to reflect the latest IMO/IEC requirements, for example, electromagnetic compatibility and environmental requirements.

##### **1.2 Principal relevant documents**

For Inmarsat C and mini-C GMDSS compliant SESs with EGC SafetyNET function, the principal relevant documents in addition to the Inmarsat C SDM are:

- .1 *Performance standards for enhanced group call equipment – annex: Recommendation on performance standards for enhanced group call equipment* (resolution A.664(16));
- .2 *Revised Performance standards for enhanced group call (EGC) equipment* (resolution MSC.306(87), as amended);

- .3 General requirements for shipborne radio equipment forming part of the global maritime distress and safety system (gmdss) and for electronic navigational aids (resolution A.694(17));
- .4 Performance standards for Inmarsat C ship earth stations capable of transmitting and receiving direct-printing communications – annex: Recommendation on performance standards for inmarsat standard-c ship earth stations capable of transmitting and receiving direct-printing communications (resolution A.807(19), as amended by resolution MSC.68(68), annex 4);
- .5 Performance standards for a ship earth station for use in the GMDSS (resolution MSC.434(98), as amended);
- .6 Shipborne Radio Equipment forming part of the Global Maritime Distress and Safety System and Marine Navigational Equipment (IEC 60945 standard);
- .7 Global Maritime Distress and Safety System (GMDSS) – Part 4: Inmarsat C Ship Earth Station and Inmarsat Enhanced Group Call (EGC) Equipment – Operational and Performance Requirements, Methods of Testing and Required Test Results (IEC 61097-4 standard); and
- .8 Maritime Design and Installation Guidelines (DIGs), Annex B, issue 6 of April 2008 published by Inmarsat at: [www.inmarsat.com/digs](http://www.inmarsat.com/digs)

## 2 Introduction

### 2.1 Enhanced group call

Enhanced group call is a message broadcast service transmitted over the Inmarsat C communications system. The service allows terrestrial information providers to pass messages or data to Class 2 or Class 3 SESs with EGC receivers or Class 0 stand-alone EGC receivers through the Inmarsat C LESs. The messages are processed at the addressed LES and forwarded to the NCS which transmits them on the common channel.

### 2.2 EGC receiver

An EGC receiver is defined as a single-channel receiver with a dedicated message processor. Ship earth stations of Class 2 and 3 provide an EGC capability in addition to To-Ship and From-Ship messaging capabilities; Class 0 SESs are self-contained EGC receivers as shown in figure 3-1.

**Note:** Most of the existing models of Inmarsat C and mini-C maritime terminals on the market are Class 2 SESs.

### 2.3 Type approval

The Inmarsat C SDM presents the technical requirements and recommendations for an EGC receiver. These requirements must be satisfied before the equipment can be utilized in the Inmarsat system. Procedures for type approval by Inmarsat of a manufacturer's design are provided in a complementary document entitled *Type Approval Procedures for Inmarsat C and Mini-C Ship Earth Stations* published by Inmarsat.

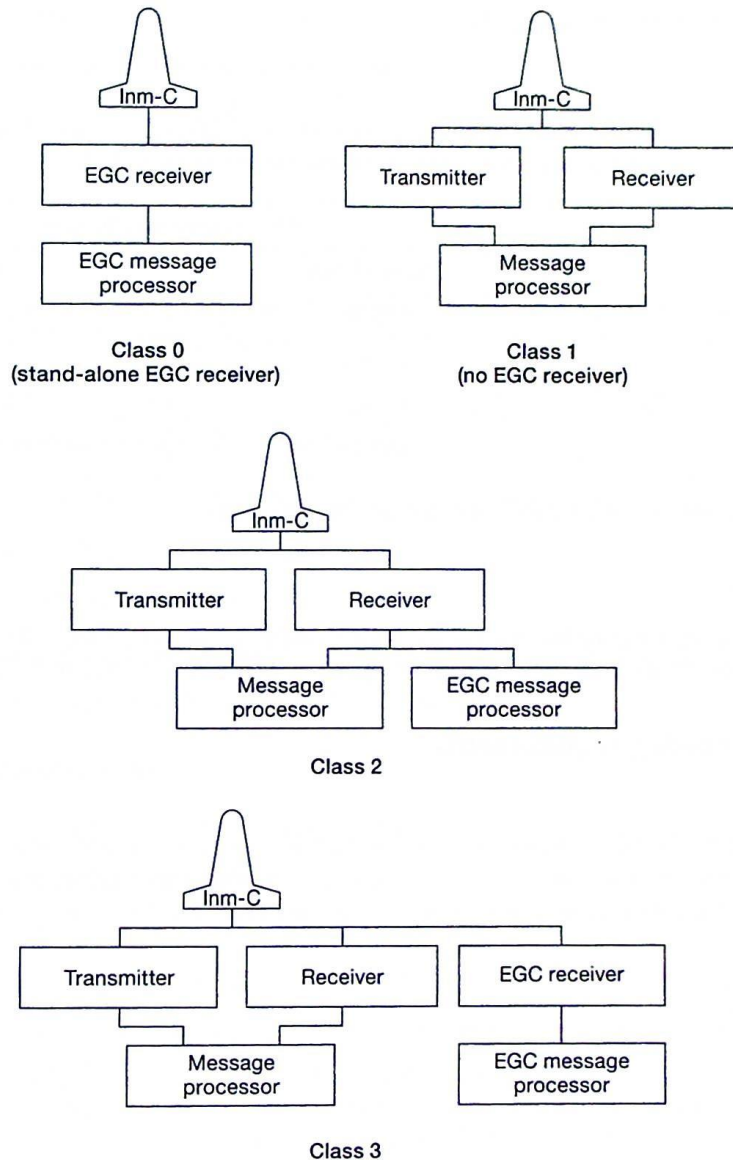

Figure 3-1 – Classes of Inmarsat C ship earth stations

### 3 General requirements

#### 3.1 Mandatory capabilities

The mandatory capabilities of SafetyNET receivers for SOLAS applications are:

- .1 continuous reception of an NCS common channel and processing of the information according to the EGC message protocol; a Class 2 Inmarsat C SES continuously receives the NCS common channel when not engaged in general communications;
- .2 automatic recognition of messages directed to fixed and absolute geographical areas and service codes as selected by the receiver operator or based upon input(s) from navigational equipment;
- .3 SafetyNET receivers meet the requirements of IEC 61097-4 and IEC 60945; and
- .4 where automatic updates are not available, provision is made for a visual indication if the ship's position has not been updated during the last 12 hours. It is only possible to reset this indication by revalidating the ship's position.



## 4 NCS common channel selection

### 4.1 General

4.1.1 EGC receivers are equipped with facilities for storing up to 20 NCS channel numbers. Four of these are permanently assigned global beam channel numbers and frequencies as follows:

NCS	NCS common channel	
	Channel No.	Frequency
AOR-West	11080	1537.70 MHz
AOR-East	12580	1541.45 MHz
POR	12580	1541.45 MHz
IOR	10840	1537.10 MHz

These four channel numbers are stored in ROM and are not alterable.

### 4.2 NCS scanning

Automatic NCS scanning on a regular basis is prohibited in SafetyNET EGC receivers. In the event of low signal strength from the satellite, an alarm is raised, and the operator is advised to initiate NCS scanning manually.

## 5 Message-processing requirements

### 5.1 General

Acceptance or rejection of the EGC service code types is under operator control except that receivers always receive navigational warnings, meteorological warnings, SAR-related information and shore-to-ship distress alert relays which are directed to a fixed or absolute geographical area within which the receiver is situated.

### 5.2 Display devices

#### 5.2.1 Message display

The display is capable of presenting at least 40 characters per line of text. The EGC receiver ensures that if a word cannot be accommodated in full on one line it is transferred to the next line.

#### 5.2.2 Status display

An indication of EGC carrier frame synchronization (or loss of synchronization) is provided.

### 5.3 Printer requirements

An integrated printer device may be used within the SafetyNET receiver. Received EGC messages may be stored for later printing with an indication to the operator that the message has been received. However, distress or urgency priority calls are directly printed as well as stored. Means are also provided not to print or store the same EGC message after it has been received error-free and printed. Alternatively, a dedicated display device and non-volatile message memory or a connection to a navigation system and non-volatile message memory may be used.

### 5.4 Character codes

For the EGC service, the International Reference Version of the International Alphabet 5 (IA5), also known as ASCII (a standard alphanumerical character set based on 7-bit codes) is used.

### 5.5 Operator control

5.5.1 The following control functions and displays are provided as a minimum:

- .1 selection of EGC carrier frequency;

and for SafetyNET receivers:

- .2 means of inputting the following information
  - .1 SES's position coordinates;
  - .2 current and planned (additional) NAVAREA(s)/METAREA(s);
  - .3 current and planned coastal warning area (B<sub>1</sub> Code); and
  - .4 coastal warning subject indicator character (B<sub>2</sub> Code).

5.5.2 Receivers are fitted with operator controls to allow the operator to select desired geographical areas and message categories. Details of the geographical areas and message categories which have been selected for reception by the operator are readily available.

## 5.6 EGC receiver memory capacity requirements

Both temporary and non-volatile memory is required in an EGC receiver for the following purposes:

- .1 Message buffering;
- .2 Maintaining message identification records;
- .3 Storing position coordinates and NAVAREA(s)/METAREA(s) data; and
- .4 Storing expansion of NCS common channel numbers.

## 5.7 EGC receiver addressing

5.7.1 The five basic methods of addressing MSI receivers are:

- .1 all-mobiles call (Inmarsat only);
- .2 Inmarsat system message addressing (Inmarsat only);
- .3 fixed geographical area (NAVAREA/METAREA);
- .4 temporary area determined by information provider – circular or rectangular; and
- .5 coastal warning area.

5.7.2 The type of address used in the header of an MSI packet is uniquely determined by the “C<sub>2</sub>” service code field.

## 5.8 Message identification

All messages are transmitted with a unique sequence number, originating LES ID and service code. Each subsequent transmission of the message contains the original sequence number. This facility allows multiple printing of repeated messages to be inhibited.

## 5.9 Geographical area addressing

5.9.1 Geographical area addressing refers to messages transmitted to SESs in a particular area. The area may be expressed in terms of a fixed, predefined area such as the NAVAREA/METAREA, or satellite coastal warning area, or in terms of an absolute geographical address expressed as latitude and longitude coordinates on the surface of the earth. An absolute geographical area address is a representation of a closed boundary on the surface of the earth given in the address field of the message header. The receiver recognizes two forms of absolute geographical addressing: rectangular and circular. Each form is specified in terms of an absolute position in latitude and longitude and further parameters that completely specify the boundary.

5.9.2 In order to process a geographical area address, the receiver should be programmed with the SES's current position. The position may be entered automatically from an integrated or external navigation aid or entered manually. The receiver provides notification to the operator when the position has not been updated

for 4 hours. If the SES's position has not been updated for more than 12 hours, or is unknown, **all** SafetyNET messages will be printed or stored in memory.

**5.9.3** A geographical area address is considered valid for a particular SES if its current position falls inside or on the boundary specified by the address. It is a mandatory requirement that the operator be able to select more than one area, so that messages directed to other area(s) of interest can be provided. It is recommended that the operator be able to select at least four areas.

## **6 Link performance monitoring**

The SafetyNET EGC receiver continuously monitors the received bulletin board error rate (BBER) as a measure of link performance whenever it is tuned and synchronized to an NCS (or LES) time division multiplex (TDM). The receiver stores a count of the number of bulletin boards received in error out of the last 100 received. This count is continuously updated frame by frame.

## **7 Alarms and indications**

The following alarms and indications are provided at a SafetyNET receiver and meet the operational requirements for alarms stated in the IEC 61097-4 standard.

### **7.1 Distress/urgency priority call alarm**

For SafetyNET receivers, provision is made for a specific audible alarm and visual indication at the position from which the ship is normally navigated to indicate receipt of SafetyNET messages with distress or urgency priority. It is not possible to disable this alarm and it is only possible to reset it manually, and then only from the position where the message is displayed or printed.

### **7.2 Other alarms and indications**

- .1 high BBER;
- .2 printer paper low;
- .3 receiver fault indication;
- .4 loss of receiver synchronization; and
- .5 position update.

Additional alarms and indications may be provided at the manufacturer's discretion.

## **8 Electromagnetic compatibility**

The interference and electromagnetic compatibility requirements of the IEC 60945 standard apply.

## **9 Environmental conditions**

SafetyNET receivers should operate satisfactorily under the environmental conditions specified in the SDM. The latest issues of IEC 61097-4 and IEC 60945 standards apply.

## **10 Navigational interface**

In order that a receiver's position may be automatically updated, receivers may be equipped with an interface to navigational instruments. A suggested standard interface is in IEC 61162 standard, Part 1 (NMEA 0183) Standard for Interfacing Electronic Marine Navigational Devices.

**Note:** The majority of modern maritime SESs have an integrated navigational receiver.

## Annex 4

### Operational guidance for SafetyNET II and RescueNET

#### 1 SafetyNET II

##### 1.1 Introduction of SafetyNET II

1.1.1 SafetyNET II provides an interactive web portal, or application programming interface (API), for information providers to promulgate their MSI messages over the Inmarsat EGC system. SafetyNET II is a user interface enhancement to the SafetyNET system including Inmarsat C, mini-C, and Fleet Safety as illustrated by figure 4-1.

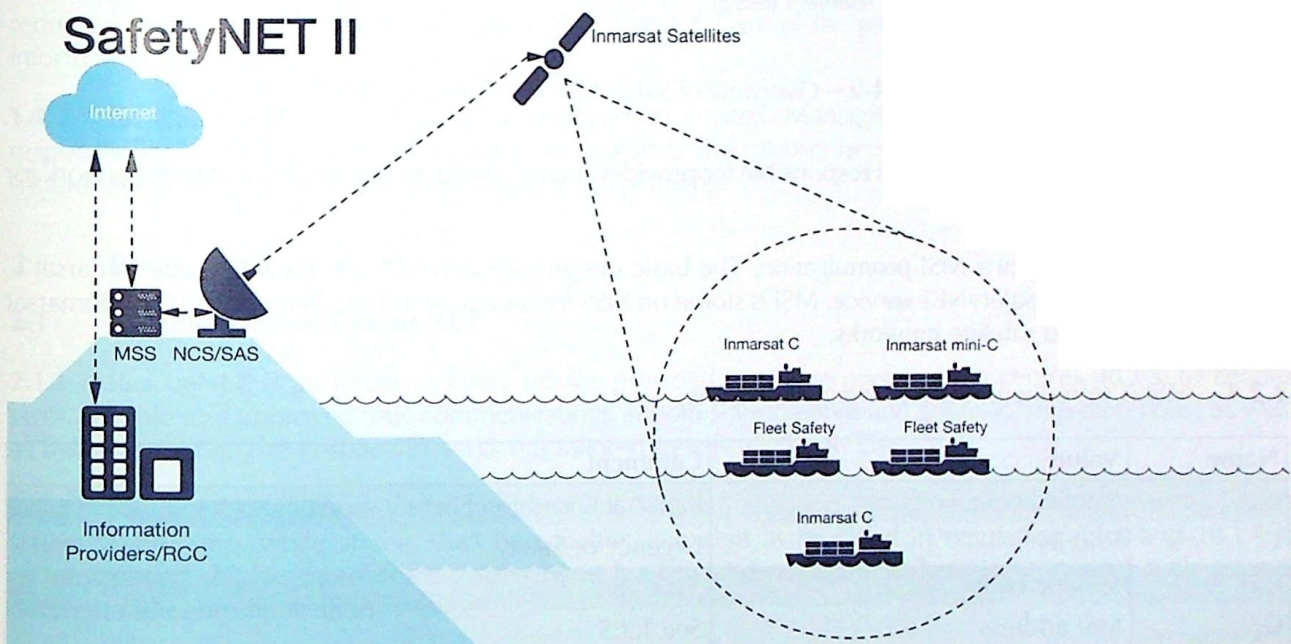

Figure 4-1 – Overview of SafetyNET II

1.1.2 SafetyNET II offers a secure web interface. The information provider is issued a personal login to the Maritime Safety Server (MSS) that will store a record of all MSI messages sent on the MSS database.

1.1.3 SafetyNET II offers information providers the ability to direct a message to a given geographical area. The area may be fixed, as in the case of a NAVAREA/METAREA or coastal warning area, or a user-defined area (circular or rectangular).

##### 1.2 SafetyNET II service overview

1.2.1 MSS is the core of SafetyNET II and RescueNET. MSS is owned and operated by Inmarsat as part of its commitment to maritime safety services and its public service agreement obligations. MSS interfaces between the shore-based maritime safety infrastructure, e.g. information providers or rescue coordination centres (RCCs), and the seafarer, who uses a Maritime Safety Terminal (MST) via the FleetBroadband system. Additionally, MSS provides interconnectivity to the Inmarsat C system for the purposes of sending and receiving MSI. MSS offers high resilience through internal application redundancy and geographical redundancy as illustrated by figure 4-2.

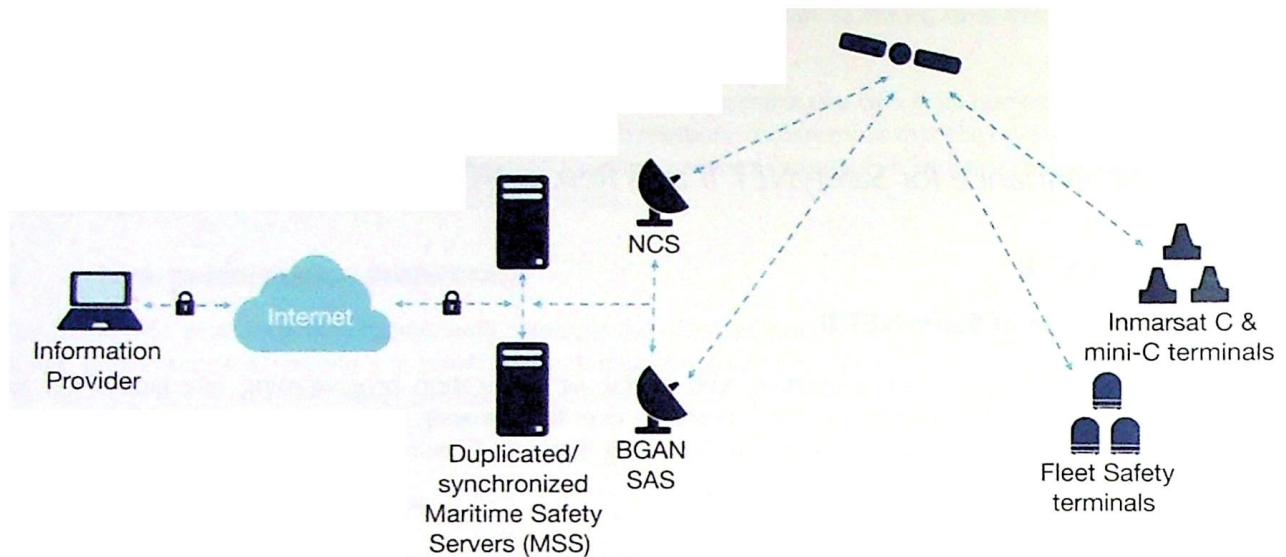

Figure 4-2 – Overview of SafetyNET II and RescueNET

1.2.2 The information provider is responsible for providing communication links to the system’s network for efficient handling of MSI.

1.2.3 The MSS supports MSI promulgation. The basic design for SafetyNET II is based on the Inmarsat C EGC and the derived SafetyNET service. MSI is stored on MSS for broadcast to User Terminal (UT) on Inmarsat C or FleetBroadband satellite networks.

1.2.4 MSI is stored with the following information:

Name	Value	Comment
C <sub>0</sub>	Satellite ocean region	Inmarsat C and Fleet Safety specific
C <sub>1</sub>	Priority	Urgency or Safety
C <sub>2</sub>	Service code	
C <sub>3</sub>	MSI address	See 1.2.5
C <sub>4</sub>	Repetition scheme	
C <sub>5</sub>	Presentation	MSIv1 supports IA5 (7bit) and 8-bit transparent data
Pay-load	Data	Max 64kbit payload for BGAN Max 32kbit payload for Inmarsat C

1.2.5 MSI can be addressed for broadcast in the following area types:

- .1 all ships (in a specified ocean region);
- .2 circular area;
- .3 rectangular area;
- .4 NAVAREA/METAREA;
- .5 coastal area (within NAVAREA/METAREA);
- .6 sub-area (within NAVAREA/METAREA); and
- .7 fixed area.

### 1.3 Operation of the SafetyNET II

1.3.1 SafetyNET II offers a standard interface application that provides a secure portal to information providers via public internet. All access will require secure login, which will be provided to the information providers by the Inmarsat customer on-boarding team.

1.3.2 Information on MSI message formatting, MSI message management and MSI message cancellation can be found in the SafetyNET II Handbook on: [www.inmarsat.com/safetynet](http://www.inmarsat.com/safetynet)

### 1.4 SafetyNET II set-up

1.4.1 Section 4, Planning of new SafetyNET EGC services, describes the authorization, certification and registration of information providers via the IMO EGC Coordinating Panel. After the authorization, certification and registration of the information provider, individual log-ins to the SafetyNET II portal will be provided for each information provider authorized contact specified at the time of service set-up.

1.4.2 A secure password will be provided to each information provider. This password can be changed by the user after the login on the SafetyNET II portal. In case the password is lost, the information provider can request a new password through the SafetyNET II portal. Care of the password is the responsibility of the information provider.

1.4.3 Additional SafetyNET II user accounts can be created. Management of user accounts will be the responsibility of the information providers, on behalf of their subscribers. Registered information providers should take into account the need for contingency planning.

## 2 RescueNET

### 2.1 Introduction of RescueNET

2.1.1 RescueNET is an Inmarsat safety service provided to rescue coordination centres (RCCs) to enable swift, reliable and approved SAR communications in both ship-to-shore and shore-to-ship directions, as well as between RCCs. The RescueNET service is tailored specifically for RCCs.

2.1.2 RescueNET facilitates the requirements of SOLAS regulation IV/4, Functional requirements, which states: "Every ship, while at sea, shall be capable: .1 except as provided in regulation 8.1.1 and 10.1.4.3, of transmitting ship-to-shore distress alerts by at least two separate and independent means, each using a different radiocommunications service".

2.1.3 RCCs registered on the RescueNET service have the capability to automatically receive distress alerts from any Inmarsat Maritime Safety Terminal (MST).

2.1.4 RescueNET includes the below features:

- .1 fast reception and coordination of distress alerts;
- .2 simultaneous broadcast of distress alert relay to Inmarsat C, mini-C and Fleet Safety;
- .3 broadcast SAR coordination messages to rectangular/circular area;
- .4 priority messaging ship-to-shore and shore-to-ship;
- .5 distress chat;
- .6 RCC and vessel look-up functions; and
- .7 nearby vessel search.

2.1.5 The innovative distress chat function makes it possible for RCCs to control SAR incidents using the facilities available on RescueNET. RCCs can communicate in real time with multiple vessels and global RCCs over FleetBroadband and remain in complete control over who joins and leaves the chat session.

## **2.2 Operation of the RescueNET services**

**2.2.1** RescueNET is available free of charge to all authorized, certified and IMO GISIS (Global Integrated Shipping Information System) registered RCCs. Customers are only authorized to use the RescueNET services for SAR operations.

**2.2.2** More information on using the RescueNET services can be found in the RescueNET Handbook on: [www.inmarsat.com/rescueenet](http://www.inmarsat.com/rescueenet)

## **2.3 RescueNET set-up**

**2.3.1** As part of RescueNET, an RCC will be enrolled on a secure interface, where the RCC will be able to access the standard RCC functionalities of RescueNET (i.e. reception of distress alerts, broadcast of distress alert relay, priority messaging, RCC lookup, vessel lookup and distress chat).

**2.3.2** RCCs will gain access to the MSI broadcasting functionality after submitting their Certificate of Authorization.

**2.3.3** After the registration of an RCC, individual log-ins to the RescueNET portal will be provided for each authorized contact specified at the time of service set-up.

**2.3.4** In case the password is lost, RCCs can request a new password through the RescueNET portal. Care of the password is the responsibility of the RCC.

**2.3.5** Additional RescueNET user accounts can be created. Management of user accounts will be the responsibility of the information providers, on behalf of their subscribers. RCCs should take into account the need for contingency planning.

## Annex 5

### Enhanced group call receiver specifications – Fleet Safety

#### Technical requirements for Fleet Safety enhanced group call receivers for SOLAS-compliant ship earth stations (SES)

##### 1 Fleet Safety EGC receivers for SOLAS installations

###### 1.1 Background

**1.1.1** The Global Maritime Distress and Safety System (GMDSS) is a radiocommunication system based on satellite and terrestrial technology, designed to improve communications relating to distress and safety of life at sea. It was adopted by the Organization in 1988, in the form of amendments to the International Convention for the Safety of Life at Sea, 1974 (SOLAS) and came into effect on 1 February 1992. Implementation was completed on 1 February 1999.

**1.1.2** The Maritime Safety Committee, at its ninety-ninth session, recognized the maritime mobile satellite service provided by the Inmarsat Fleet Safety Service for use in GMDSS. Although Fleet Safety works globally, it is, as yet, only recognized for use in GMDSS in the coverage area under the Inmarsat-4 Middle East and Asia (MEAS) region satellite as shown in figure 5-1.

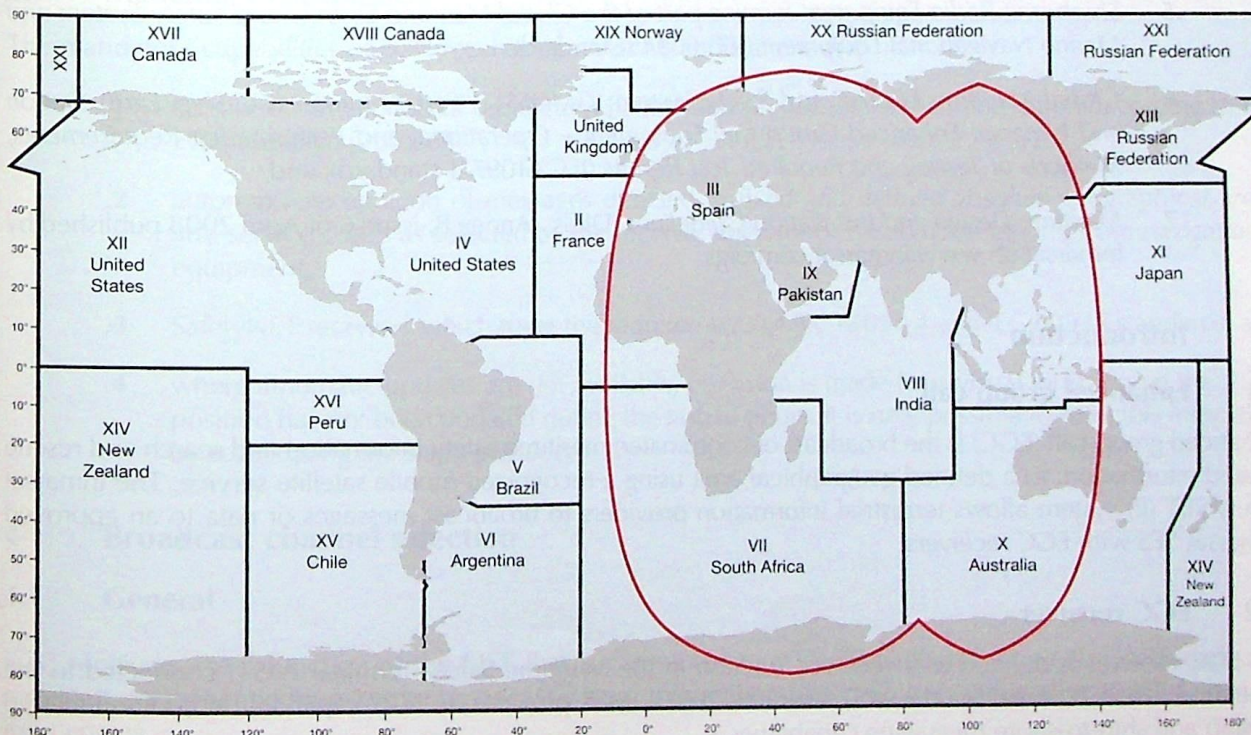

Figure 5-1 – Fleet Safety GMDSS approved area until Inmarsat-6 satellite constellation deployed

**1.1.3** It is the responsibility of national Administrations to determine whether a radio installation on board a ship meets the SOLAS requirements. This is done by national Type Acceptance or Approval testing of the subsystems included in the installation and by inspection of the complete installation by a radio surveyor.



**1.1.4** National Type Acceptance testing for SOLAS equipment is usually based on GMDSS specifications and procedures prepared by IMO and the International Electrotechnical Commission (IEC) on their behalf, although other national or regional specifications may be invoked as well.

**1.1.5** The IMO and IEC documents identified in section 1.2 summarize not only the general requirements for GMDSS equipment, but also the special requirements for EGC receivers for use in SOLAS installations, as specified by IMO/IEC.

**1.1.6** A number of the Inmarsat specifications have been completely revised to reflect the latest IMO/IEC requirements, for example, electromagnetic compatibility and environmental requirements.

## **1.2 Principal relevant documents**

For Inmarsat Fleet Safety GMDSS SES with EGC capability, the principal relevant documents in addition to the Inmarsat Broadband Global Area Network (BGAN) System Definition Manual (SDM) are:

- .1 *Performance standards for enhanced group call equipment – annex: Recommendation on performance standards for enhanced group call equipment* (resolution A.664(16));
- .2 *Revised Performance standards for enhanced group call (EGC) equipment* (resolution MSC.306(87), as amended);
- .3 *General requirements for shipborne radio equipment forming part of the Global Maritime Distress and Safety System (GMDSS) and for electronic navigational aids* (resolution A.694(17));
- .4 *Performance standards for a ship earth station for use in the GMDSS* (resolution MSC.434(98), as amended);
- .5 *Shipborne Radio Equipment forming part of the Global Maritime Distress and Safety System and Marine Navigational Equipment* (IEC 60945 standard);
- .6 *Global Maritime Distress and Safety System (GMDSS) – Part 4: Inmarsat C Ship Earth Station and Inmarsat Enhanced Group Call Equipment – Operational and Performance Requirements, Methods of Testing and Required Test Results* (IEC 61097-4 standard); and
- .7 *Maritime Design and Installation Guidelines (DIGs), Annex B, issue 6 of April 2008* published by Inmarsat at: [www.inmarsat.com/digs](http://www.inmarsat.com/digs)

## **2 Introduction**

### **2.1 Enhanced group call**

Enhanced group call (EGC) is the broadcast of coordinated maritime safety information and search and rescue related information, to a defined geographical area using a recognized mobile satellite service. The Inmarsat SafetyNET (II) system allows terrestrial information providers to broadcast messages or data to an approved Inmarsat SES with EGC receivers.

### **2.2 EGC receiver**

An EGC receiver is defined as a receiver function in the Maritime Safety Terminal (MST) connected to the FleetBroadband Terminal via the MST interface (MSTI). MST provides an EGC capability in addition to ship-to-ship and ship-to-shore messaging capabilities.

### **2.3 Inmarsat type approval**

The Inmarsat BGAN SDM presents the technical requirements and recommendations for MST. These requirements should be satisfied before the equipment can be utilized in the Inmarsat system. Procedures for type approval by Inmarsat of a manufacturer's design are provided in a complementary document entitled *FleetBroadband Alpha Beta Testing*, produced by Inmarsat.

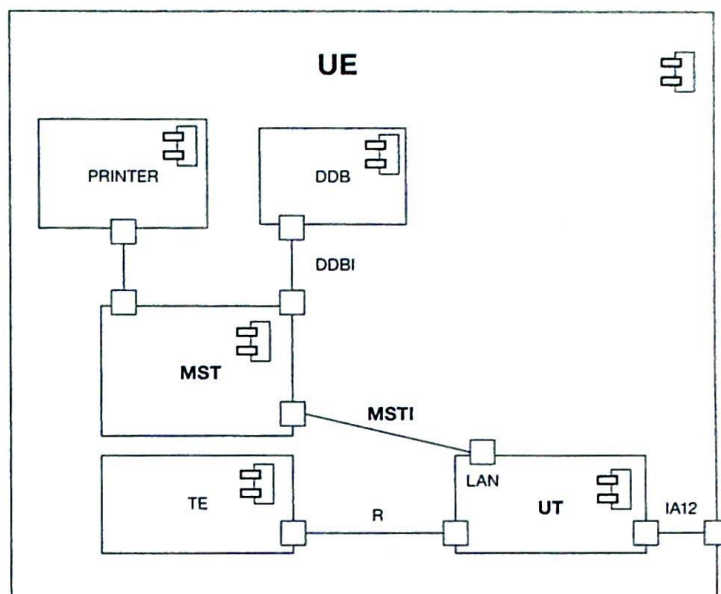

Figure 5-2 – Extended architecture of the user equipment (FleetBroadband Terminal)

### 3 General requirements

#### 3.1 Mandatory capabilities

The mandatory capabilities of EGC receivers for SOLAS applications are:

- .1 continuous reception of broadcast channel and processing of the information according to the EGC message protocol;
- .2 automatic recognition of messages directed to fixed and defined absolute geographical areas and service codes as selected by the receiver operator or based upon input(s) from navigational equipment;
- .3 SafetyNET receivers which meet the requirements of IEC 61097-4 and IEC 60945 standards; and
- .4 where automatic updates are not available, provision is made for a visual indication if the ship's position has not been updated during the last 12 hours. It is only possible to reset this indication by revalidating the ship's position.

### 4 Broadcast channel selection

#### 4.1 General

EGC receivers are a function of the MST that is connected to a FleetBroadband terminal. FleetBroadband terminals permanently monitor the broadcast system information based on a dynamic allocation of channel frequencies.

#### 4.2 Global broadcast scanning

Automatic scanning of the system information and automated satellite selection is a mandatory feature of all FleetBroadband User Terminals (UTs). In the event of loss of forward carrier connectivity from the satellite exceeding 30s, the UT attempts to retune to another satellite and re-establish the link to the ground automatically.

## 5 Message-processing requirements

### 5.1 General

Acceptance or rejection of the EGC service code types is under operator control, except that receivers always receive: navigational warnings, meteorological warnings and forecast; SAR-related information and shore-to-ship distress alerts, directed to a fixed or defined geographical area within which the receiver is situated. The user can also select additional areas (see section 5.9 below).

### 5.2 Display devices

#### 5.2.1 Message display

The display is capable of presenting at least 40 characters per line of text. The EGC receiver ensures that if a word cannot be accommodated in full on one line it is transferred to the next line.

#### 5.2.2 Status display

MST is able to provide indication on the link status, i.e. various levels of connectivity to the Inmarsat network, which could trigger alarms to the users.

### 5.3 Printer requirements

**5.3.1** A printer is required for an EGC receiver. Received EGC messages may be stored for later printing with an indication to the operator that the message has been received. However, distress or urgency priority calls are directly printed as well as stored. Means are also provided not to print or store the same EGC message after it has been received error-free and printed.

**5.3.2** Messages are not printed until completely received.

**5.3.3** A local audible alarm is sounded to give advance warning of a printer “paper-low” condition.

**5.3.4** All EGC messages are annotated with the date and time (UTC) of reception. This information is displayed or printed with the message.

### 5.4 Character codes

For the EGC service, the International Reference Version of the International Alphabet 5 (IA5), also known as ASCII (a standard alphanumerical character set based on 7-bit codes) is used.

### 5.5 Operator control

**5.5.1** The following control functions and displays are provided as a minimum:

- .1 selection of EGC carrier frequency;

and for SafetyNET receivers:

- .2 means of inputting the following information:
  - .1 MES’s position coordinates;
  - .2 current and planned (additional) NAVAREA(s)/METAREA(s);
  - .3 current and planned coastal warning area (B<sub>1</sub> Code); and
  - .4 coastal warning subject indicator character (B<sub>2</sub> Code).

**5.5.2** Receivers are fitted with operator controls to allow the operator to select desired geographical areas and message categories. Details of the geographical areas and message categories which have been selected for reception by the operator are readily available.

## 5.6 EGC receiver memory capacity requirements

5.6.1 The EGC receiver should be capable of storing safety related activity and messages. Information stored should include:

- .1 date/time of activity;
- .2 activity type (message received, etc., plus priority);
- .3 message header information;
- .4 message size and contents;
- .5 date/time of operator acknowledgement for received distress and urgency messages;
- .6 date/time when operator read received messages (no date/time means not read); and
- .7 message history.

5.6.2 The database can record at least 500 messages of average length 500 characters (printable and non-printable). It should not be possible for the user to erase messages from the memory. If the database becomes full the oldest messages are overwritten by new messages.

5.6.3 The user can tag individual messages for permanent retention. These messages may occupy up to 25% of the available database and should not be overwritten by new messages. When no longer required, the user should be able to remove the tag on these “saved” messages, which may then be overwritten in the normal manner.

## 5.7 EGC receiver addressing

5.7.1 The five basic methods of addressing EGC receivers are:

- .1 all-mobiles call (Inmarsat only);
- .2 Inmarsat system message addressing (Inmarsat only);
- .3 fixed geographical area (NAV/METAREA);
- .4 defined geographical area determined by the information provider – circular or rectangular; and
- .5 coastal warning area.

5.7.2 The type of address used in the header of the information provided is uniquely determined by the “C<sub>2</sub>” service code field.

## 5.8 Message identification

All messages are transmitted with a unique reference number and originating ID. Each subsequent transmission of the message contains the original sequence number. This facility allows multiple printing of repeated messages to be inhibited.

## 5.9 Geographical area addressing

5.9.1 Geographical area addressing refers to messages transmitted to EGC receivers in a particular area. The area may be expressed in terms of a fixed, predefined area such as the NAVAREA/METAREA, or satellite coastal warning area, or in terms of a defined geographical address expressed as latitude and longitude coordinates on the surface of the earth. A defined geographical area address is a representation of a closed boundary on the surface of the earth given in the address field of the message header. The EGC receiver recognizes two forms of defined geographical addressing: rectangular and circular. Each form is specified in terms of an absolute position in latitude and longitude and further parameters that completely specify the boundary.

**5.9.2** In order to process a geographical area address, the EGC receiver should be provided with its current position. The position may be entered automatically from an integrated or external navigation aid or entered manually. The EGC receiver provides notification to the operator when the position has not been updated for 4 hours. If the position has not been updated for more than 12 hours or is unknown, **all** EGC messages will be printed or stored in the memory.

**5.9.3** A geographical area address is considered valid for a particular EGC receiver if its current position falls inside or on the boundary specified by the address. It is a mandatory requirement that the operator be able to select more than one area, so that messages directed to other area(s) of interest can be provided. It is recommended that the operator be able to select at least four areas.

## **6 Link performance monitoring**

The EGC receiver continuously monitors the received bulletin board whenever it is tuned and synchronized to the Satellite Access Station (SAS). The EGC receiver stores at least 500 messages of average length 500 characters (printable and non-printable) in this database. It should not be possible for the user to erase messages from the memory. If the database becomes full, the oldest messages should be overwritten by new messages.

## **7 Alarms and indications**

The following alarms and indications are provided at an EGC receiver and meet the operational requirements for alarms stated in IEC 61097-4 standard.

### **7.1 Distress/urgency priority call alarm**

For EGC receivers, provision is made for a specific audible alarm and visual indication at the position from which the ship is normally navigated to indicate receipt of EGC messages with distress or urgency priority. It is not possible to disable this alarm and it is only possible to reset it manually, and then only from the position where the message is displayed or printed.

### **7.2 Other alarms and indications**

- .1 user's SIM card not present;
- .2 registration failure;
- .3 loss of signal;
- .4 packet switch connection failure;
- .5 circuit switch connection failure;
- .6 distress voice call failure; and
- .7 printer failure.

Additional alarms and indications may be provided at the manufacturer's discretion.

## **8 Electromagnetic compatibility**

The interference and electromagnetic compatibility requirements of IEC 60945 standard apply.

## **9 Environmental conditions**

EGC receivers should operate satisfactorily under the environmental conditions specified in SDM. The latest issues of IEC 61097-4 and IEC 60945 standards apply.

## 10 Navigational interface

In order that an EGC receiver's position may be automatically updated, receivers may be equipped with an interface to navigational instruments. A suggested standard interface is in IEC 61162 standard, Part 1 (NMEA 0183) Standard for Interfacing Electronic Marine Navigational Devices.

**Note:** All FleetBroadband terminals have an integrated navigational receiver.

## Technical requirements for Fleet Safety Radio Installations on board SOLAS ships

### 1 Satellite communication antennas

1.1 In general, satellite antennas should be located so that they have a 360° free view for the satellite at all times. In practice this can be difficult to achieve due to shadow sectors from nearby structures.

1.2 For Fleet Safety (BGAN antenna) it is recommended that communication should be maintained with the satellite down to an elevation of minus 5° in the fore and aft direction and minus 15° in the port and starboard direction.

### 2 Satellite communication antenna installation

The following guidelines should be observed in order to fulfil the above recommendations:

- .1 the antenna should be located at the top of the radar mast or on a pedestal, in the radar mast, or on the top deck so that:
  - .1 for directive antennas: shadows from constructions, especially within a distance of 10 metres, are maximum 6°; and
  - .2 for omnidirectional antennas: shadows from constructions, especially within a distance of 1 metre, are maximum 2°;
- .2 the antenna should be installed in a readily accessible location;
- .3 the satellite antenna should not be located in an area where it can be damaged by heat and smoke;
- .4 the satellite antenna should not be located on the same plane as the ship's radar antenna;
- .5 the GNSS antenna should not be located close to or on the same plane as the Inmarsat antenna; and
- .6 consideration should be given to installing the Inmarsat antenna on a suitable pedestal.

(Resolutions A.663(16), A.698(17), A.807(19), as amended, A.808(19) and MSC.130(75) and the *Inmarsat Design and Installation Guidelines*.)

**Note:** The mast or pedestal should be constructed so that vibrations are reduced as much as possible.

### 3 Safe antenna distances

The following "safe distance" from Inmarsat antennas to other antennas and to the compass are recommended:

- .1 distance to the HF antenna should be more than 5 metres;
- .2 distance to VHF antennas should be more than 4 metres; and
- .3 distance to the magnetic compass should be more than 3 metres.

### 4 Fleet Safety

#### 4.1 Antenna

4.1.1 Fleet Safety antennas are 2-axis stabilized BGAN antennas varying in size and throughput: FleetBroadband 150, FleetBroadband 250, FleetBroadband 500 and Fleet One.

4.1.2 All FleetBroadband antennas rotate 360° and down to –25° in pitch and roll, to allow for continuous pointing even in heavy sea conditions. Any obstructions within this volume can cause signal degradation.

## 4.2 Obstructions

4.2.1 The antenna should be mounted as far away as possible from the ship's radar and high-power radio transmitters (including other Inmarsat-based systems), because they may compromise the antenna performance. RF emission from radars might actually damage the antenna. Since a radar radiates a fan beam with a horizontal beam width of a few degrees and a vertical beam width of up to  $\pm 15^\circ$ , the worst interference can be avoided by mounting the antenna at a different level, i.e. the antenna is installed minimum  $15^\circ$  above or below the radar antenna.

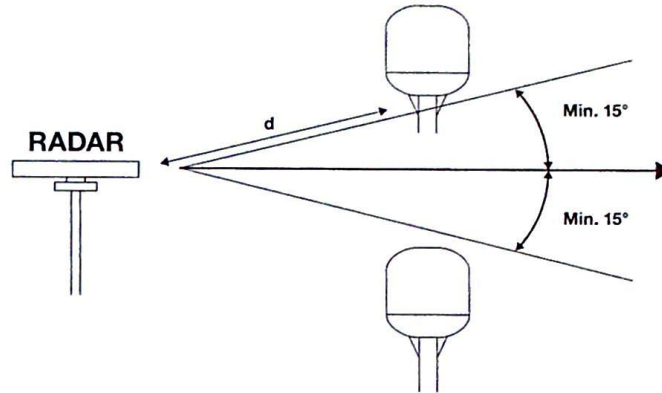

4.2.2 The FleetBroadband antenna itself may also interfere with other radio systems. Other Inmarsat systems and GNSS receivers with poor frequency discrimination are especially vulnerable to the radiation generated by the FleetBroadband antennas.

## 4.3 Antenna cable

A coaxial cable for connection between the antenna and terminal is delivered with the system. The manufacturer's specifications regarding total attenuation and maximum DC resistance (short-circuit in one end) should be complied with. The maximum allowed RF-loss in the antenna cable is 20 dB at 1660 MHz. This is to ensure the performance of the system.

## 5 Antennas for voluntary radio equipment

Antennas for voluntary radio equipment may be located on deck, provided that their use does not interfere with antennas of mandatory radio equipment. When mobile telephones are installed on board ships, special attention should be made to the fact that some types of mobile telephones (especially GSM telephone equipment) may interfere with the ship's navigational equipment (especially GNSS) and other electronic equipment.





## **Annex 6**

### *Procedure for amending the International SafetyNET Services Manual*

**1** Proposals for amendment or enhancement of the *International SafetyNET Services Manual* should be submitted for evaluation by the Sub-Committee on Navigation, Communications and Search and Rescue (NCSR). Amendments should only be implemented after consideration and approval by the Maritime Safety Committee.

**2** Amendments to the Manual should normally be approved at intervals of approximately two years or at such longer periods as may be determined by the Maritime Safety Committee. Amendments approved by the Maritime Safety Committee will be notified to all concerned and will become effective on 1 January of the following year, or at another date as decided by the Committee.

**3** The agreement of the International Hydrographic Organization, the International Mobile Satellite Organization, the World Meteorological Organization and the active participation of other bodies should be sought, according to the nature of the proposed amendments.



# Related information



## **MSC.1/Circ.1635**

*11 November 2020*

### **IMO Enhanced Group Call Coordinating Panel**

**1** The Maritime Safety Committee, at its 102nd session (4 to 11 November 2020), in approving the revised *International SafetyNET Services Manual* (MSC.1/Circ.1364/Rev.2), agreed, inter alia, to remove and relocate the terms of reference for the IMO Enhanced Group Call Coordinating Panel and the procedures for authorization, certification and registration of enhanced group call information providers under a separate circular.

**2** Consequentially, the Committee approved the terms of reference of the IMO Enhanced Group Call Coordinating Panel and the procedures for authorization, certification and registration of enhanced group call information providers, including procedures for amendment, prepared by the Sub-Committee on Navigation, Communications and Search and Rescue (NCSR), at its seventh session (15 to 24 January 2020), as set out in annexes 1, 2 and 3, respectively.

**3** The Committee agreed that the attached terms of reference and procedures should be applicable as from 1 January 2021, when the revised *International SafetyNET Services Manual* contained in MSC.1/Circ.1364/Rev.2 will become effective.

**4** Member States and international organizations are invited to bring this circular to the attention of all parties concerned.

## Annex 1

### IMO Enhanced Group Call Coordinating Panel

#### 1 Terms of reference

To coordinate the development and use of the international enhanced group call (EGC)\* service, and in particular to:

- .1 develop operating methods for the effective use of EGC services, including consideration of the need for scheduled broadcasts;
- .2 develop documentation in support of EGC services, in particular the IMO manuals of the recognized mobile satellite service provider(s);
- .3 advise recognized mobile satellite service provider(s) and potential registered information providers on all aspects of EGC services, including system access and effective operation;
- .4 develop criteria and establish means for the approval and registration of potential information providers to ensure worldwide coverage is achieved and maintained, and ensure agreements are conducted with all recognized mobile satellite service provider(s) serving the required sea area;
- .5 coordinate the registration of potential information providers; and
- .6 promote a proper understanding of the benefits and use of EGC services among the wider maritime community.

#### 2 Contact address

The IMO Enhanced Group Call Coordinating Panel can be contacted at the following address:

The Chair  
IMO Enhanced Group Call Coordinating Panel  
International Maritime Organization  
4 Albert Embankment  
London SE1 7SR  
United Kingdom

Telephone: +44 (0)20 7735 7611

Fax: +44 (0)20 7587 3210

Email: ncsr@imo.org (in subject line add: for Chair, IMO Enhanced Group Call Coordinating Panel)

#### 3 Panel membership

3.1 The IMO Enhanced Group Call Coordinating Panel is open to membership by all Member Governments and also includes one member nominated by each of the following international organizations:

- .1 International Maritime Organization (IMO);
- .2 International Hydrographic Organization (IHO);
- .3 World Meteorological Organization (WMO); and
- .4 International Mobile Satellite Organization (IMSO).

3.2 The following may be represented as observers on the panel:

- .1 IHO Worldwide Navigational Warning Service Sub-Committee;
- .2 IMO NAVTEX Coordinating Panel;
- .3 WMO Services Commission (SERCOM); and
- .4 a single representative from each recognized mobile satellite service provider.

---

\* Enhanced group call (EGC) means the broadcast of coordinated maritime safety information and search and rescue related information, to a defined geographical area using a recognized mobile satellite service.

## **Annex 2**

### *Authorization, certification and registration of enhanced group call information providers*

Two distinct and separate processes, authorization and certification, should be completed before an information provider will be granted registration to access the international enhanced group call (EGC) service. They have been established to protect the integrity of the EGC information service and clearly establish a qualification to the special EGC tariff.

#### **1 Authorization**

1.1 Authorization is carried out by IMO in consultation with IHO and WMO, as appropriate.

1.2 In order to obtain authorization to broadcast maritime safety information (MSI) and/or search and rescue (SAR) related information through the International EGC service, an information provider should apply to the relevant international organization for approval to participate in the internationally coordinated service:

- .1 Hydrographic authorities – to IHO;
- .2 Meteorological authorities – to WMO;
- .3 Search and rescue authorities – to IMO;
- .4 The International Ice Patrol – to IMO; and
- .5 Others – to IMO.

1.3 In considering such applications, the relevant international organizations will take into account:

- .1 the established and expected availability of other information sources for the area concerned; and
- .2 the need to minimize duplication of information as much as possible.

1.4 The relevant international organization will inform IMO of endorsed applications.

#### **2 Certification**

2.1 On receipt of IMO authorization, the IMO Enhanced Group Call Coordinating Panel will issue a Certificate of Authorization to participate in the international EGC service directly to the information provider with a copy to IMO or IHO or WMO, as well as to the recognized mobile satellite service provider(s) concerned. A specimen Certificate of Authorization is shown in section 5.

2.2 The IMO Enhanced Group Call Coordinating Panel will maintain the master list of all registered information providers and circulate it to the IMO, IHO and WMO Secretariats, and the recognized mobile satellite service provider(s) concerned.

#### **3 Registration**

3.1 After receiving a Certificate of Authorization, an information provider should conclude an agreement with the recognized mobile satellite service provider(s) concerned, serving the required sea area(s), to obtain access to the system.

3.2 This will involve, in addition to the contractual aspects, registration of the information provider's identity which should be programmed into the control equipment of the recognized mobile satellite service provider(s).

3.3 Recognized mobile satellite service provider(s) will only register information providers who have received a Certificate of Authorization from the IMO Enhanced Group Call Coordinating Panel.



## 4 Contact addresses

### **International Maritime Organization**

The Chair  
IMO Enhanced Group Call Coordinating Panel  
4 Albert Embankment  
London SE1 7SR  
United Kingdom

Telephone: +44 (0)20 7735 7611

Fax: +44 (0)20 7587 3210

Email: [ncsr@imo.org](mailto:ncsr@imo.org) (in subject line add: for Chair, IMO Enhanced Group Call Coordinating Panel)

### **International Hydrographic Organization**

4b quai Antoine 1er  
BP 445  
MC98011 Monaco Cedex  
Principauté de MONACO

Telephone: +377 93 10 81 00

Fax: +377 93 10 81 40

Email: [info@iho.int](mailto:info@iho.int)

### **World Meteorological Organization**

7bis, avenue de la Paix  
Case postale 2300  
CH-1211 Geneva 2  
Switzerland

Telephone: +41(0) 22 730 81 11

Fax: +41(0) 22 730 81 81

Email: [mmo@wmo.int](mailto:mmo@wmo.int)

## 5 Sample Certificate of Authorization

	<b>INTERNATIONAL MARITIME ORGANIZATION</b>	Issue Date: ..... (date)
		Certificate No: ..... (number)
<b>Certificate of Authorization</b>		
This Certificate of Authorization allows:		
.....		
<i>(name of MSI or SAR provider)</i>		
to broadcast [maritime safety information and/or search and rescue related information] through the international enhanced group call service in accordance with the IMO manual of the recognized mobile satellite service providers.		
.....		.....
<i>(Name of the Chair)</i> Chair IMO Enhanced Group Call Coordinating Panel		Name of MSI or SAR provider Address

## **Annex 3**

### *Procedure for amendment*

- 1** Proposals for amendment or enhancement of the annexes to this circular should be submitted for evaluation by the Sub-Committee on Navigation, Communications and Search and Rescue (NCSR). Amendments should only be implemented after consideration and approval by the Maritime Safety Committee.
- 2** Amendments to this circular should normally be approved at intervals of approximately two years or at such longer periods as may be determined by the Maritime Safety Committee. Amendments approved by the Maritime Safety Committee will be notified to all concerned and will become effective on 1 January of the following year, or at another date as decided by the Committee.
- 3** The agreement of the International Hydrographic Organization, the International Mobile Satellite Organization, the World Meteorological Organization and the active participation of other bodies should be sought, according to the nature of the proposed amendments.













Notes

---